

4/S3
v 3.3 (en)

VARIABLE AIR VOLUME CONTROL DAMPER PRESSURE DAMPER

RVP-C, RVP-P, RVK
RVP-C-T, RVP-P-T





RVP-C

- Volume flow control regulation by a given set-point
- Factory parametrization in accordance with clients request
- High regulation precision
- No maintainance required

Options

- Constant
- Master-slave
- Insulated casing (50mm)
- MP-Bus (standard), LONWORKS, ModBus (Belimo/Siemens), KNX (Belimo/Siemens), MF (no Bus, Belimo), SGB (no Bus, Siemens), Bacnet (Siemens)

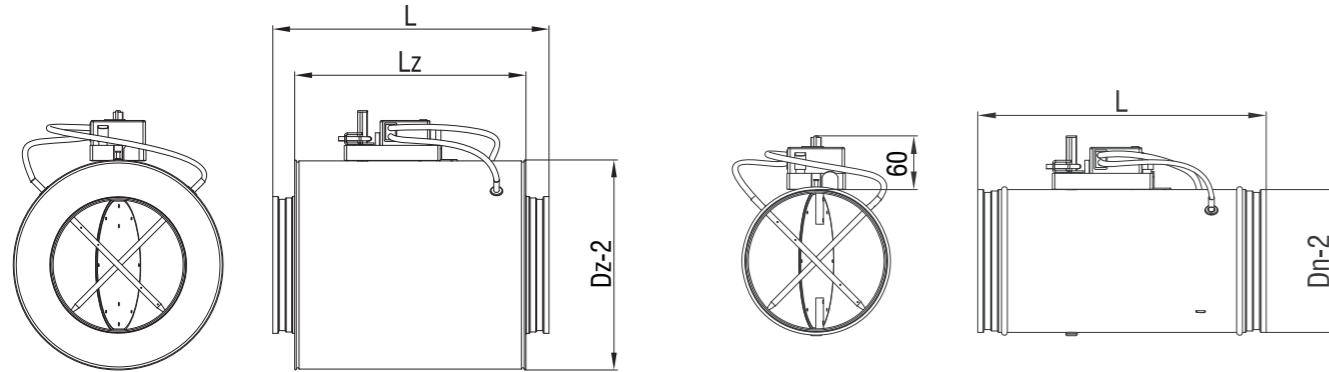

Specifications

øD _n [mm]	L [mm]	øD _z	L _z [mm]	V _{min} [m ³]	V _{max}
100	400	198	330	37	343
125	400	223	330	54	540
160	400	258	330	90	900
200	400	298	330	145	1459
250	500	348	430	217	2215
315	600	413	530	380	3680
355	600	453	530	482	4275
400	600	498	530	615	6047
500	800	598	740	973	9484
630	850	728	810	1435	12482

Actuators overview

Type	ød 100 - 500	ød 630
MF	Belimo LMV-D3-MF	Belimo NMV-D3-MF
SGB	Siemens GDB181.1E/3	Siemens GLB181.1E/3
MP	Belimo LMV-D3-MP	Belimo NMV-D3-MP
MOD-S	Siemens GDB181.1E/MO	Siemens GLB181.1E/MO
MOD-B	Belimo LMV-D3-MOD	Belimo NMV-D3-MOD
KNX-S	Siemens GDB181.1E/KN	Siemens GLB181.1E/KN
KNX-B	Belimo LMV-D3-KNX	Belimo NMV-D3-KNX
BAC	Siemens GDB181.1E/BA	Siemens GLB181.1E/BA
LON	Belimo LMV-D3-LON	Belimo NMV-D3-LON
PP	Gruner 227VM-024-05	Gruner 227VM-024-10

* Maximum volume flow at velocity v_{max} = 12 m/s
 ** Size 630 comes with reinforcement ring

Definition of symbols:

- | | | | |
|--------------------------------------|--------------------------------|--------------------------------------|--------------------------------|
| Δp [Pa] | - Total pressure drop | Δp _s [Pa] | - Static pressure differential |
| v _{ef} [m/s] | - Effective outlet velocity | V _{max} [m ³ /h] | - Maximal airflow rate |
| V [m ³ /h] | - Airflow rate | øD _n [mm] | - Damper diameter |
| f [Hz] | - Sound frequency | L [mm] | - Damper length |
| L _w [dB/okt] | - Sound power level per octave | øD _z [mm] | - Insulation diameter |
| L _{WA} [dB(A)] | - Sound power level | L _z [mm] | - Insulation length |
| V _{min} [m ³ /h] | - Minimal airflow rate | B x H [mm] | - Dimensions |

Compact VAV solutions - Belimo

	Belimo L(N)MV-D3-MF	Belimo L(N)MV-D3-MP	Belimo L(N)MV-D3-MOD	Belimo L(N)MV-D3-LON	Belimo L(N)MV-D3-KNX	Siemens GL(D)B181.1E/3	Siemens GL(D)B181.1E/MO	Siemens GL(D)B181.1E/KN	Siemens GL(D)B181.1E/BA	Gruner 227VM-024-05 (10)
Applications										
VAV/CAV control	•	•	•	•	•	•	•	•	•	•
Actuators										
Torque	5(10) Nm	5(10) Nm	5(10) Nm	5(10) Nm	5(10) Nm	5(10) Nm	5(10) Nm	5(10) Nm	5(10) Nm	5(10) Nm
Running time	Variable	Variable	Variable	Variable	Variable	Variable	Variable	Variable	Variable	Variable
Control										
0/2..10V	•	•				•				•
Via contacts (CAV)	•	•								•
MP-Bus		•								
Modbus RTU			•				•			
LonWorks				•						
KNX					•			•		
Bacnet									•	
PP Bus										•
Pressure sensor										
	0..450Pa	0..450Pa	0..450Pa	0..450Pa	0..450Pa	0..300Pa	0..300Pa	0..300Pa	0..300Pa	0..250Pa
Accessories										
KOER Codis C35-VAV	•	•				•			•	•
Room temperature controller / CR24..	•	•								
Fan optimiser / COU24-A-MP	•	•								
MP gateways / UK24xxx	•	•								
PC Tool / MFT-P	•	•	•	•	•					
Service tool / ZTH-GEN	•	•	•	•	•					
Siemens software ASC941						•	•	•	•	
AST20						•	•	•	•	
Supply / Inputs										
AC/DC 24V	•	•	•	•	•	•	•	•	•	•
Feedback signal	Airflow / Damper position / Δp	Airflow / Damper position / Δp	Modbus / Not relevant	LonWorks /Not relevant	KNX /Not relevant	Airflow	Modbus / Not relevant	KNX /Not relevant	Bacnet /Not relevant	Airflow

RVP-C INSTALLATION

SOUND POWER LEVELS

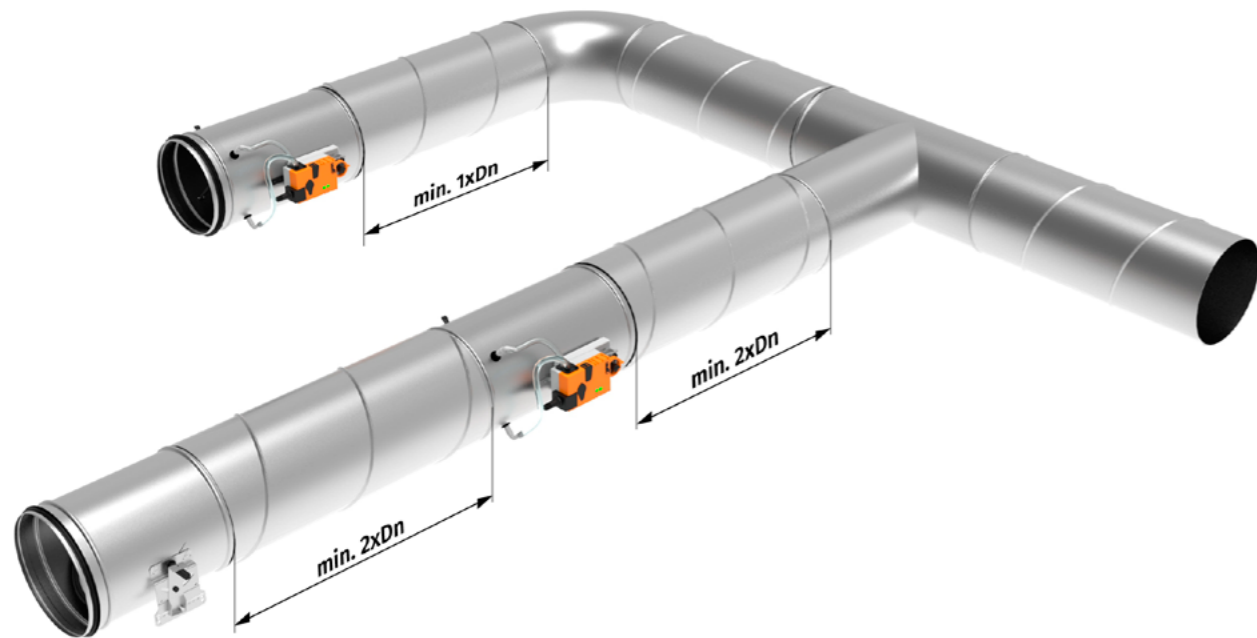

*Wiring diagrams are on the page 282.

Ordering key

Variable air volume damper	RVP	- C	- ØDn	- MP	- Z	- V	- P
C - round							
Diameter							
MP-Bus (standard)							
LONWORKS							
ModBus (Belimo/Siemens)							
KNX (Belimo/Siemens)							
MF (no Bus, Belimo)							
SGB (no Bus, Siemens)							
Bacnet (Siemens)							
Insulation							
Volume flow V*min/max [m³/h]							
Mode							
P - single							
M - master							
S - slave							
K - constant flow							

Sound power levels L_w [dB/Okt]:
RVP-C Ø100 - Ø200

Size	Ø100				Ø125				Ø160				Ø200						
v [m/s]	3	6	9	12	3	6	9	12	3	6	9	12	3	6	9	12			
V [m³/h]	85	170	257	344	130	263	396	530	216	434	652	871	337	680	1027	1370			
p _s = 125 Pa	L _w [dB/Okt]	f _c [Hz]	63	34	41	46	50	40	48	52	58	43	51	55	61	49	57	61	67
			125	40	53	55	55	42	56	57	58	44	58	59	60	46	60	61	62
			250	37	49	50	54	38	51	53	57	41	53	55	59	43	55	57	61
			500	35	44	46	50	37	48	47	53	39	49	49	55	41	51	51	57
			1000	34	40	41	46	35	42	42	47	38	44	44	49	40	46	46	51
			2000	33	37	37	40	35	38	39	42	37	40	41	44	39	42	43	46
			4000	32	35	25	36	34	37	37	39	36	39	39	41	38	41	41	43
			8000	33	34	34	35	35	37	38	38	37	38	39	39	37	39	40	40
	L _{WA} [dB(A)]	39	46	48	51	40	47	52	55	45	48	52	55	44	52	56	58		
p _s = 250 Pa	L _w [dB/Okt]	f _c [Hz]	63	38	44	49	58	45	52	56	65	49	55	59	69	55	61	66	76
			125	43	56	62	66	46	59	64	68	48	62	66	71	50	64	70	74
			250	42	53	58	62	45	57	60	64	47	57	62	67	49	60	65	70
			500	41	50	56	58	43	52	58	60	45	54	61	62	47	56	54	64
			1000	39	47	51	52	42	49	53	54	44	51	56	56	44	53	55	58
			2000	38	44	48	48	40	46	50	51	42	48	52	53	43	51	54	54
			4000	36	42	45	46	39	44	49	49	40	46	49	52	41	49	53	51
			8000	32	37	40	43	38	43	47	55	38	42	44	48	42	48	52	53
	L _{WA} [dB(A)]	47	53	56	58	47	54	59	60	51	56	59	62	53	60	63	65		
p _s = 500 Pa	L _w [dB/Okt]	f _c [Hz]	63	42	46	54	57	50	54	62	65	56	60	68	71	61	65	73	76
			125	47	62	70	72	51	64	72	74	53	66	74	76	55	68	76	77
			250	46	59	67	68	50	61	69	70	50	63	71	72	54	65	72	72
			500	45	56	61	63	48	59	64	65	49	60	65	66	52	61	67	68
			1000	44	62	56	58	46	55	59	60	48	56	60	61	50	48	62	64
			2000	43	51	53	55	45	53	55	57	47	55	57	59	49	47	59	61
			4000	41	46	50	52	42	49	52	55	45	50	54	57	46	42	56	59
			8000	40	45	49	51	41	46	50	52	45	50	54	56	46	41	55	58
	L _{WA} [dB(A)]	51	57	61	64	53	60	63	66	55	61	65	68	57	63	67	70		
p _s = 1000 Pa	L _w [dB/Okt]	f _c [Hz]	63	59	63	70	74	61	65	72	76	63	67	74	78	65	69	75	80
			125	56	62	70	71	58	63	72	75	60	66	74	77	62	68	76	79
			250	52	61	68	70	54	62	71	74	57	65	73	76	59	67	75	78
			500	51	59	64	69	53	62	68	73	56	63	70	75	58	65	71	76
			1000	52	58	63	67	54	60	67	71	58	62	69	72	58	64	70	74
			2000	51	57	62	66	53	59	66	69	57	61	68	71	57	63	69	72
			4000	49	55	59	63	51	58	62	66	55	59	64	67	56	61	65	68
			8000	49	56	58	62	50	57	61	65	54	59	63	67	56	61	65	67
	L _{WA} [dB(A)]	56	63	69	75	58	65	73	79	62	69	75	81	63	70	77	83		

* if not otherwise specified, regulator is set to standard factory values V_{max} and V_{min}.

Sound power levels L_w [dB/Okt]:
RVP-C Ø250 - Ø355

Size		Ø250				Ø315				Ø355				
v [m/s]		3	6	9	12	3	6	9	12	3	6	9	12	
V [m³/h]		529	1065	1604	2144	843	1692	2543	3394	1073	2160	3252	4347	
$p_s = 125$ Pa	L_w [dB/Okt] f_{cr} [Hz]	63	52	62	65	71	55	64	68	73	57	65	69	74
		125	47	63	54	64	51	65	66	67	52	66	67	68
		250	45	58	60	63	48	60	62	65	49	61	63	67
		500	44	54	53	59	45	55	56	62	46	56	56	62
		1000	43	48	49	53	43	49	50	56	45	50	51	55
		2000	41	44	44	48	42	46	46	50	43	46	46	50
		4000	39	42	42	54	42	44	44	46	42	45	45	47
		8000	38	40	40	51	40	40	41	41	40	40	42	42
		L_{WA} [dB(A)]	46	54	58	61	50	54	48	63	49	56	59	62
	$p_s = 250$ Pa	L_w [dB/Okt] f_{cr} [Hz]	63	54	60	64	72	56	64	69	79	62	58	73
125			49	62	54	65	48	61	66	72	56	59	75	79
250			46	58	60	63	42	54	63	63	55	55	71	75
500			43	53	52	58	45	53	60	60	51	51	67	69
1000			41	49	47	52	46	53	57	57	49	56	61	63
2000			40	44	44	47	46	53	55	55	48	54	59	60
4000			39	42	43	53	41	47	54	54	47	53	58	58
8000			38	39	40	50	44	51	52	55	48	52	56	58
L_{WA} [dB(A)]			46	52	57	61	55	64	65	69	58	63	66	70
$p_s = 500$ Pa		L_w [dB/Okt] f_{cr} [Hz]	63	64	68	76	79	67	71	79	82	68	72	80
	125		57	70	78	80	59	72	80	82	60	73	81	83
	250		56	67	75	76	57	69	76	78	59	70	78	78
	500		55	64	69	71	55	66	70	73	57	68	72	74
	1000		53	60	64	66	54	62	66	68	56	64	67	69
	2000		51	59	61	63	53	60	63	65	54	62	64	66
	4000		48	54	58	61	51	56	60	63	51	59	61	64
	8000		48	53	57	59	50	55	59	61	51	58	60	62
	L_{WA} [dB(A)]		59	65	69	72	61	67	71	74	62	69	72	77
	$p_s = 1000$ Pa	L_w [dB/Okt] f_{cr} [Hz]	63	67	71	78	82	69	73	79	83	69	74	81
125			64	70	78	81	66	72	79	82	66	73	80	84
250			61	69	77	80	63	71	77	79	62	72	78	83
500			60	68	73	78	62	69	75	78	61	70	75	80
1000			60	66	72	76	62	68	73	76	62	69	75	78
2000			59	65	71	74	61	67	72	75	61	68	74	77
4000			57	63	66	71	59	66	67	72	59	67	69	74
8000			56	63	65	68	58	65	66	72	58	66	68	74
L_{WA} [dB(A)]			66	73	79	84	68	75	80	86	68	76	82	88

Sound power levels L_w [dB/Okt]:
RVP-C Ø400 - Ø630

Size		Ø400				Ø500				Ø630				
v [m/s]		3	6	9	12	3	6	9	12	3	6	9	12	
V [m³/h]		1364	2736	4111	5488	2111	4255	6412	8577	3365	6804	10273	13759	
$p_s = 125$ Pa	L_w [dB/Okt] f_{cr} [Hz]	63	58	66	70	76	60	68	72	77	62	70	74	80
		125	53	67	67	69	55	70	70	71	57	72	71	73
		250	50	62	64	67	51	63	65	68	54	66	67	70
		500	47	56	58	63	49	58	58	65	51	62	62	66
		1000	45	51	53	56	47	53	53	60	50	57	55	60
		2000	44	47	49	51	46	49	50	54	48	52	52	56
		4000	43	46	46	48	45	47	48	50	47	50	49	52
		8000	42	42	43	43	42	42	44	44	45	45	45	46
		L_{WA} [dB(A)]	51	56	62	65	54	60	62	65	56	62	64	68
	$p_s = 250$ Pa	L_w [dB/Okt] f_{cr} [Hz]	63	65	71	76	86	65	71	76	86	67	73	78
125			56	69	77	80	59	73	78	82	60	74	80	84
250			55	67	72	76	58	69	74	78	59	71	76	80
500			52	63	69	71	54	64	70	72	56	66	72	74
1000			50	58	62	64	52	59	64	66	54	61	66	69
2000			49	55	59	60	51	57	61	62	53	59	62	64
4000			49	54	57	58	50	56	59	60	52	58	61	62
8000			49	54	56	59	49	55	58	60	51	56	60	63
L_{WA} [dB(A)]			59	66	68	72	60	66	71	74	63	68	72	76
$p_s = 500$ Pa		L_w [dB/Okt] f_{cr} [Hz]	63	60	74	82	85	71	75	83	86	73	77	85
	125		61	74	82	84	63	76	84	86	65	78	86	88
	250		60	70	79	80	62	73	81	82	63	74	82	83
	500		58	67	73	75	60	70	75	77	61	72	77	78
	1000		57	64	68	70	58	66	70	72	60	68	72	74
	2000		55	63	65	67	57	65	67	69	59	67	69	71
	4000		52	59	62	65	55	60	64	67	57	62	66	69
	8000		52	57	61	63	54	59	63	65	56	61	65	67
	L_{WA} [dB(A)]		63	69	73	77	65	71	75	78	67	73	77	81
	$p_s = 1000$ Pa	L_w [dB/Okt] f_{cr} [Hz]	63	71	75	82	86	73	77	84	88	75	79	86
125			68	74	81	85	68	76	83	87	72	78	86	89
250			65	73	79	84	65	75	81	85	69	77	84	88
500			64	71	76	82	65	73	78	83	68	75	80	86
1000			64	70	75	79	66	73	77	81	68	74	79	83
2000			63	69	75	78	65	71	76	80	67	73	79	82
4000			61	59	72	75	63	69	73	77	65	72	74	78
8000			60	59	71	75	63	69	73	76	64	71	73	77
L_{WA} [dB(A)]			70	77	83	89	72	79	85	91	74	81	87	93

Correction values for case radiated noise in dB

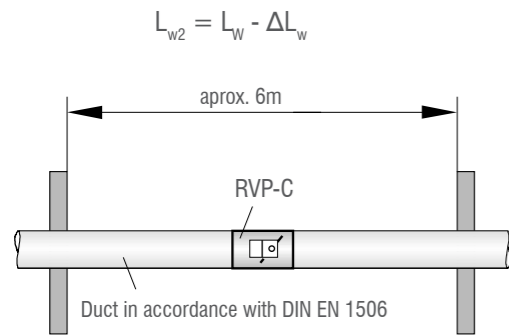

Size	ΔL_w							
	100	125	160	200	250	315	400	
ΔL_w [dB], in relation to f_m [Hz]	63	31	30	30	29	25	22	20
	125	30	29	29	28	24	22	19
	250	27	25	24	23	20	19	18
	500	21	21	21	22	18	17	17
	1000	19	18	19	21	16	15	15
	2000	11	12	16	18	14	13	12
	4000	11	12	14	16	12	11	10
	8000	9	10	12	13	11	10	10

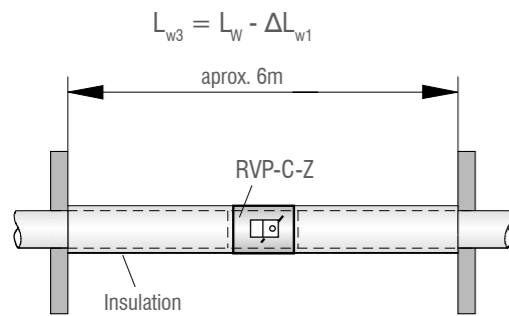

Size	ΔL_{w1}							
	100	125	160	200	250	315	400	
ΔL_{w1} [dB], in relation to f_m [Hz]	63	33	32	32	31	27	24	22
	125	28	29	32	31	27	25	23
	250	26	24	24	26	23	23	22
	500	26	27	28	33	29	29	29
	1000	34	33	34	39	35	34	35
	2000	33	33	38	44	42	41	39
	4000	37	37	40	43	36	35	33
	8000	31	32	34	35	31	29	29



RVP-P

- Volume flow control regulation by a given set-point
- Factory parametrization in accordance with clients request
- High regulation precision
- No maintenance required

Options

- Constant mod
- Master-slave mod
- Insulated casing (30mm)
- MP-Bus (standard), LONWORKS, ModBus (Belimo/Siemens), KNX (Belimo/Siemens), MF (no Bus, Belimo), SGB (no Bus, Siemens), Bacnet (Siemens)

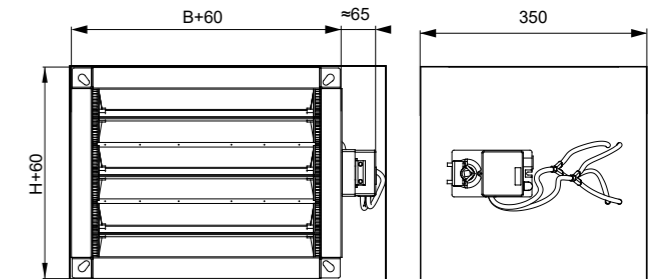
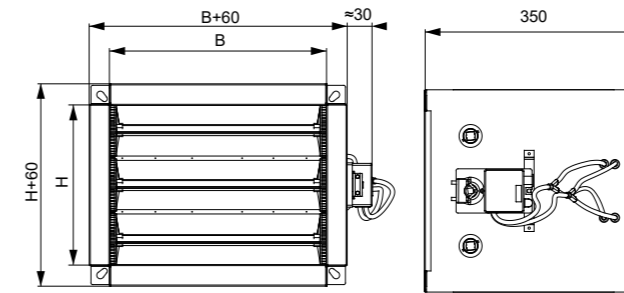

Specifications

B [mm]	H [mm]	A_{gr} [mm ²]	Vmin [m ³ /h]	Vmax [m ³ /h]
200	100	0,0170	130	720
300		0,0255	190	1080
400		0,0340	255	1440
200	200	0,0340	255	1440
300		0,0510	380	2160
400		0,0680	505	2880
500	300	0,0850	630	3600
600		0,1020	755	4320
300		0,0765	570	3240
400	400	0,1020	755	4320
500		0,1275	940	5400
600		0,1530	1130	6480
700	500	0,1785	1320	7560
800		0,2040	1505	8640
900		0,2295	1695	9720
1000	600	0,2550	1880	10800
400		0,1360	1005	5760
500		0,1700	1255	7200
600	700	0,2040	1505	8640
700		0,2380	1755	10080
800		0,2720	2005	11520
900	800	0,3060	2260	12960
1000		0,3400	2510	14400
500		0,2125	1570	9000
600	900	0,2550	1880	10800
700		0,2975	2195	12600
800		0,3400	2510	14400
900	1000	0,3825	2820	16200
1000		0,4250	3135	18000
600		0,3060	2260	12960
700	600	0,3570	2635	15120
800		0,4080	3010	17280
900		0,4590	3385	19440
1000	700	0,5100	3760	21600
700		0,4165	3070	17640
800		0,4760	3510	20160
900	800	0,5355	3950	22680
1000		0,5950	4385	25200
800		0,5440	4010	23040
900	900	0,6120	4515	25920
1000		0,6800	5015	28800
900		0,6885	5075	29160
1000	1000	0,7650	5640	32400
1000		0,8500	6265	36000

B [mm]	H [mm]	A_{gr} [mm ²]	Vmin [m ³ /h]	Vmax [m ³ /h]
1000	400	0,3401	2510	14400
500		0,2125	1570	9000
600		0,2550	1880	10800
700	500	0,2975	2195	12600
800		0,3400	2510	14400
900		0,3825	2820	16200
1000	600	0,4250	3135	18000
600		0,3060	2260	12960
700		0,3570	2635	15120
800	700	0,4080	3010	17280
900		0,4590	3385	19440
1000		0,5100	3760	21600
700	800	0,4165	3070	17640
800		0,4760	3510	20160
900		0,5355	3950	22680
1000	900	0,5950	4385	25200
800		0,5440	4010	23040
900		0,6120	4515	25920
1000	1000	0,6800	5015	28800
900		0,6885	5075	29160
1000		0,7650	5640	32400
1000	0,8500	6265	36000	

Sound pressure level calculation

Given:

RVP 200
 $v = 6$ m/s
 $\Delta p_s = 250$ Pa

Required sound pressure level in room is 35 dB(A)

f_m	63	125	250	500	1000	2000	4000	8000
L_w (str. 5)	61	64	60	56	53	51	49	48
ΔL_w	29	28	23	22	21	18	16	13
L_{w2}	32	26	37	34	32	33	33	35
Ceiling reduction	4	4	4	4	4	4	4	4
Room attenuation	6	6	5	5	4	4	4	4
A-weighting	-26	-16	-9	-3	0	1	1	-1
Correction value	-4	0	19	22	24	26	26	26

- $L_{pA2} \approx 32$ dB(A), requirement is met

RVP-P INSTALLATION

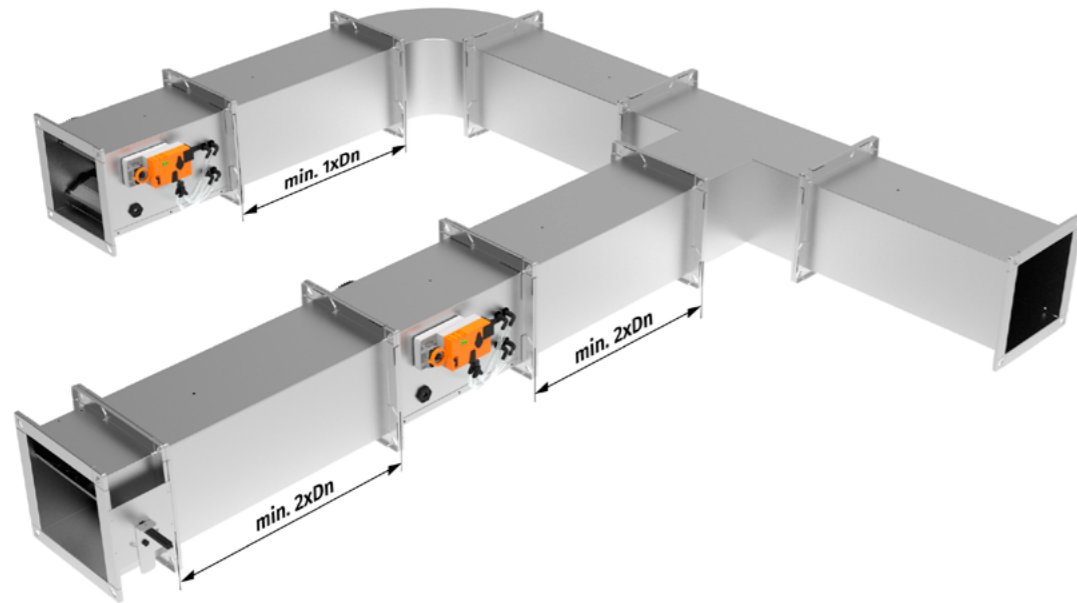

*Wiring diagrams are on the page 282.

Ordering key

Variable air volume control damper **RVP - P - BxH - MP - Z - V - P - PZX**

P - rectangular

Dimensions

Communication type

MP-Bus (standard)

LONWORKS

ModBus (Belimo/Siemens)

KNX (Belimo/Siemens)

MF (no Bus, Belimo)

SGB (no Bus, Siemens)

Bacnet (Siemens)

Insulation

Volume flow V*min/max [m³/h]

Mode

P - single

M - master

S - slave

K - constant flow

Additional silencer

* if not otherwise specified, regulator is set to standard factory values V_{max} and V_{min} .

RVP-P SOUND POWER LEVELS

in relation to		Correction values for other case widths																								
		B [mm]	$\Delta p_s = 125Pa$								$\Delta p_s = 250Pa$								$\Delta p_s = 500Pa$							
			63	125	250	500	1000	2000	4000	8000	63	125	250	500	1000	2000	4000	8000	63	125	250	500	1000	2000	4000	8000
B = 600 [mm]	200	-8	-4	-6	-2	-2	-5	-4	-6	-5	-6	-3	-3	-4	-3	-4	-6	-5	-10	-5	-3	-4	-3	-3		
	300	-5	-3	-4	-1	-1	-3	-3	-4	-3	-4	-2	-2	-3	-2	-3	-4	-3	-6	-3	-2	-3	-2	-2		
	400	-3	-2	-2	-1	-1	-2	-2	-2	-2	-2	-1	-1	-2	-1	-1	-2	-2	-4	-2	-1	-2	-1	-1		
	500	-1	-1	-1	0	0	-1	-1	-1	-1	-1	0	0	-1	-1	-1	-1	-1	-2	-1	0	-1	0	-1		
	600	0	0	0	0	0	0	0	0	0	0	0	0	0	0	0	0	0	0	0	0	0	0	0		
	700	1	1	1	0	0	1	1	1	1	1	1	0	0	1	0	1	1	1	1	1	1	0	0		
	800	2	1	2	0	1	1	1	2	1	1	2	1	1	1	1	1	2	1	3	1	1	1	1		
	900	3	2	2	1	1	2	2	2	2	2	2	1	1	2	1	1	2	2	4	2	1	2	1		
	1000	4	2	3	1	1	2	2	3	3	3	1	1	2	2	2	3	2	4	2	1	2	1	2		
B = 1000 [mm]	800	-2	-1	0	-1	-1	-1	-1	-1	-1	-1	-1	-1	-1	-1	-1	-1	-1	-1	-2	-1	-1	-1			
	900	-1	-1	0	-1	0	0	-1	-1	-1	-1	0	0	0	0	0	-1	-1	0	-1	0	0	0			
	1000	0	0	0	0	0	0	0	0	0	0	0	0	0	0	0	0	0	0	0	0	0	0			

Size B x H [mm]		600																					
		100				200				300				400				500					
v [m/s]		3	6	9	12	3	6	9	12	3	6	9	12	3	6	9	12	3	6	9	12		
$p_s = 125 Pa$	L_w [dB/Okt]	f_w [Hz]	63	45	55	63	68	51	60	68	73	53	63	71	76	56	65	73	78	59	68	76	81
			125	46	56	63	68	49	58	66	71	51	60	68	73	52	61	69	74	53	63	71	75
			250	42	49	54	57	46	53	58	61	48	55	60	63	50	56	62	64	52	59	64	67
			500	44	47	50	52	45	48	51	53	45	49	51	53	46	49	52	53	46	50	52	54
			1000	46	49	51	53	48	50	53	54	48	51	53	55	49	52	54	55	50	52	55	56
			2000	46	49	51	53	49	52	54	56	51	54	56	58	52	55	57	59	54	57	59	60
			4000	39	43	47	49	41	46	50	52	43	47	51	53	44	49	52	55	45	50	54	56
			8000	32	37	41	43	36	41	45	47	38	43	47	50	40	45	49	51	42	47	51	54
			$p_s = 250 Pa$	L_w [dB/Okt]	f_w [Hz]	63	52	61	68	72	56	64	71	75	58	66	73	77	59	68	75	79	61
125	49	58				65	70	53	61	69	73	55	64	71	75	56	65	72	77	58	67	74	79
250	46	53				58	62	49	56	62	66	51	58	64	68	53	60	66	69	55	62	68	72
500	48	52				56	58	50	54	58	60	51	55	59	61	51	56	59	62	52	57	61	63
1000	51	54				57	59	52	56	59	61	53	57	60	61	54	57	60	62	55	58	61	63
2000	53	56				58	59	56	58	61	62	57	60	62	64	58	61	63	65	60	63	65	66
4000	49	52				55	57	51	54	57	59	52	56	59	60	53	56	59	61	54	58	61	63
8000	45	49				52	54	47	51	54	56	49	53	56	58	50	64	57	59	51	55	58	60
$p_s = 500 Pa$	L_w [dB/Okt]	f_w [Hz]				63	57	65	72	76	60	69	76	80	63	71	78	82	64	73	80	84	67
			125	53	63	71	77	56	66	74	80	58	68	76	81	59	69	77	83	61	71	79	84
			250	49	58	66	70	55	64	72	76	59	68	75	80	61	70	78	82	54	74	81	86
			500	53	59	63	66	56	62	66	69	58	63	68	71	59	65	69	72	61	66	71	73
			1000	59	62	64	66	61	64	66	67	62	64	67	68	62	65	68	69	63	66	69	70
			2000	64	65	66	66	66	67	68	69	68	69	70	70	69	70	71	71	70	71	72	73
			4000	63	64	65	66	65	66	67	68	66	67	68	69	67	68	69	69	68	69	70	70
			8000	59	61	63	64	61	63	65	66	62	65	66	68	63	65	67	69	64	67	69	70

Size B x H [mm]		600				1000																	
		600				700				800				900				1000					
v [m/s]		3	6	9	12	3	6	9	12	3	6	9	12	3	6	9	12	3	6	9	12		
p _s = 125 Pa	L _w [dB/Okt]	f _r [Hz]	63	59	68	76	81	62	71	79	84	64	74	82	87	65	75	83	88	66	76	83	88
			125	53	63	71	75	55	65	73	77	57	66	74	79	57	67	75	80	57	67	75	80
			250	52	59	64	67	54	61	66	69	56	63	68	71	57	64	69	72	58	64	69	73
			500	46	50	52	54	47	51	53	55	47	51	53	55	48	51	54	55	48	51	54	55
			1000	50	52	55	56	51	53	56	57	51	54	56	57	51	54	56	58	51	54	56	58
			2000	54	57	59	60	56	59	61	62	57	60	62	64	58	61	63	65	58	61	63	65
			4000	45	50	54	56	47	52	56	58	49	53	57	59	49	54	58	60	49	54	58	60
			8000	42	47	51	54	45	50	54	56	47	52	56	58	48	53	57	59	48	53	57	59
p _s = 250 Pa	L _w [dB/Okt]	f _r [Hz]	63	61	70	77	81	63	72	79	83	65	74	80	85	66	75	81	86	66	75	82	86
			125	58	67	74	79	60	69	77	81	62	71	79	83	63	72	80	84	64	72	80	84
			250	55	62	68	72	57	65	70	74	59	67	72	76	60	68	73	77	61	68	73	77
			500	52	57	61	63	54	58	62	64	55	59	63	65	55	60	63	66	55	60	63	66
			1000	55	58	61	63	56	59	62	64	57	60	63	65	57	61	64	65	57	61	64	65
			2000	60	63	65	66	62	65	67	68	63	66	68	69	64	67	69	70	64	67	69	70
			4000	54	58	61	63	56	59	62	64	57	60	63	65	57	61	64	66	57	61	64	66
			8000	51	55	58	60	53	57	60	62	54	58	61	63	55	59	62	64	55	59	62	64
p _s = 500 Pa	L _w [dB/Okt]	f _r [Hz]	63	67	75	82	86	69	78	85	89	71	80	87	91	72	81	88	92	72	81	88	92
			125	61	71	79	84	63	73	81	86	64	74	83	88	65	75	84	89	65	75	84	89
			250	65	74	81	86	69	78	85	90	72	81	88	93	73	82	89	94	74	83	90	95
			500	61	66	71	73	63	68	73	75	64	70	74	77	65	71	75	78	65	71	75	78
			1000	63	66	69	70	64	67	70	71	65	68	70	72	66	69	71	72	66	69	71	72
			2000	70	71	72	73	72	73	74	75	73	75	75	76	74	75	76	77	74	75	76	77
			4000	68	69	70	70	69	70	71	72	70	71	72	73	70	72	73	73	70	72	73	73
			8000	64	67	69	70	66	68	70	71	67	69	71	72	68	70	72	73	68	70	72	73

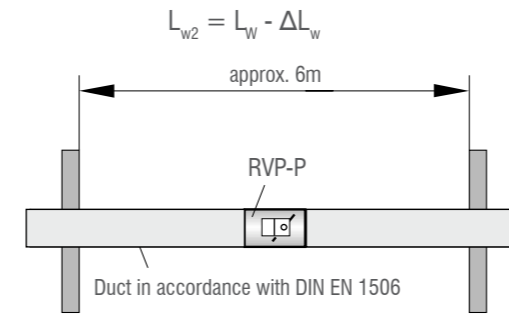

$\Delta L_w / \Delta L_{w1}$	$\Delta L_w / \Delta L_{w1}$ u dB, in relation to f_m u Hz							
	63	125	250	500	1000	2000	4000	8000
ΔL_w [dB(A)]	3	3	6	9	12	14	15	14

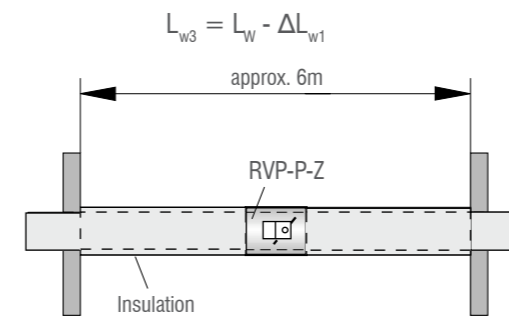

$\Delta L_w / \Delta L_{w1}$	$\Delta L_w / \Delta L_{w1}$ u dB, in relation to f_m u Hz							
	63	125	250	500	1000	2000	4000	8000
ΔL_{w1} [dB(A)]	7	7	14	21	25	28	28	25

Sound pressure level calculation

Given:

RVP-P-Z 500x300
 v = 6 m/s
 $\Delta p_s = 500$ Pa

Required sound pressure level in room is 42 dB(A)

f _m [Hz]	63	125	250	500	1000	2000	4000	8000
L _w (str. 11)	71	68	68	63	64	69	67	65
Correction B=500	-1	-1	-2	-1	0	-1	0	-1
$\Delta L_w / \Delta L_{w1}$	7	7	14	21	25	28	28	25
L _{w3}	63	60	52	41	39	40	39	39
Ceiling reduction	4	4	4	4	4	4	4	4
Room attenuation	6	6	5	5	4	4	4	4
A-weighting	-26	-16	-9	-3	0	1	1	-1
Correction value	27	34	34	29	31	33	32	30

- L_{pA3} ≈ 40 dB(A), requirement is met

RECTANGULAR VAV DAMPER ATTENUATOR - PZX

Rectangular variable air volume control damper (RVP) with attenuator (PZX):

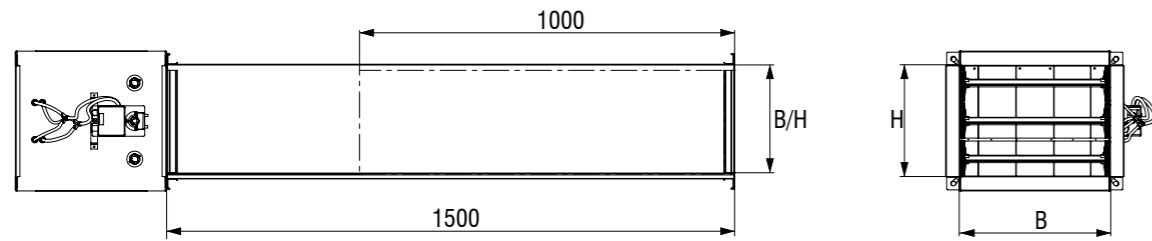

Dimensions

B [mm]	200	300	400	500	600	700	800	900	1000
H [mm]	100 200	100 200 300	100 200 300 400	100 200 300 400	100 200 300 400 500 600	200 300 400 500 600 700	200 300 400 500 600 700	300 400 500 600 700 800 900	300 400 500 600 700 800 900 1000

L = 1500mm attenuator length
L₁ = 1000mm attenuator splitter length

Sound power level with PZX attenuator

B x H mm	v m/s	$\Delta p_s = 125 \text{ Pa}$								$\Delta p_s = 250 \text{ Pa}$								$\Delta p_s = 500 \text{ Pa}$								
		$L_{w1} \text{ [dB]}$								$L_{w1} \text{ [dB]}$								$L_{w1} \text{ [dB]}$								
		$f_m \text{ [Hz]}$								$f_m \text{ [Hz]}$								$f_m \text{ [Hz]}$								
		63	125	250	500	1000	2000	4000	8000	63	125	250	500	1000	2000	4000	8000	63	125	250	500	1000	2000	4000	8000	
600	100	2	44	42	34	17	5	0	0	9	48	44	36	21	9	7	10	23	54	48	41	27	16	17	26	39
		4	53	50	40	29	24	20	16	19	57	53	43	33	26	24	24	30	62	58	50	37	30	29	34	42
		7	59	57	45	39	40	35	31	26	64	60	49	42	40	37	35	35	69	66	57	44	41	38	40	45
		10	64	62	48	45	50	45	40	31	68	64	53	48	49	46	43	39	73	71	61	49	48	45	44	46
	200	2	48	43	37	19	8	4	2	11	52	47	40	24	12	10	13	23	59	52	46	30	19	20	28	39
		4	56	52	43	31	27	23	20	20	60	56	47	36	30	27	31	67	62	55	40	33	32	35	42	
		7	63	59	47	41	43	39	34	28	68	63	52	45	44	41	38	73	70	62	48	44	42	41	44	
		10	68	63	50	47	53	49	43	33	72	67	56	51	52	49	45	40	78	75	66	53	51	48	45	46
	300	2	50	44	38	20	9	6	4	12	54	49	42	26	14	12	14	24	61	55	49	32	21	22	29	38
		4	59	53	44	32	29	25	22	22	63	58	49	37	31	29	28	31	69	65	58	42	35	34	36	41
		7	65	60	49	42	44	41	36	29	70	64	54	46	45	43	39	76	73	65	50	46	44	42	44	
		10	70	64	52	48	54	51	45	34	74	69	58	52	54	51	46	40	80	78	69	55	53	50	46	45
400	2	52	45	39	21	11	8	5	13	56	50	43	27	15	14	15	24	63	56	51	34	23	23	29	38	
	4	60	54	45	33	30	27	23	22	64	59	50	38	33	31	29	31	71	66	60	44	36	36	37	41	
	7	67	61	50	43	45	43	37	30	71	66	56	48	47	44	40	37	78	74	67	51	48	45	43	44	
	10	71	65	53	49	55	53	46	35	76	70	59	53	56	53	47	41	82	79	72	56	55	51	47	45	
500	2	53	46	40	22	11	9	7	14	57	51	44	28	16	15	16	25	65	58	53	35	24	25	30	38	
	4	61	54	46	34	31	28	24	23	65	60	51	39	34	32	30	32	73	68	61	45	38	37	38	41	
	7	68	61	51	44	46	44	38	30	73	67	57	48	48	45	41	38	79	76	69	53	49	46	44	44	
	10	73	66	54	50	56	54	48	35	77	71	60	54	57	54	48	41	84	81	73	58	56	53	47	45	
600	2	54	46	41	22	12	10	7	14	58	52	45	28	17	16	16	25	66	59	54	36	25	26	30	38	
	4	62	55	47	34	32	29	25	23	66	61	52	40	35	32	30	32	74	69	63	46	38	38	38	41	
	7	69	62	51	44	47	45	39	31	74	68	57	49	49	46	42	38	81	77	70	53	50	47	44	43	
	10	74	66	54	50	57	55	48	36	78	72	61	55	57	54	49	41	85	82	75	58	57	53	48	45	
1000	800	2	58	48	44	24	16	14	11	16	62	56	48	31	21	20	19	26	71	63	60	40	28	29	32	37
		4	67	57	50	37	35	33	29	26	71	64	56	43	38	36	33	33	79	73	69	50	42	42	40	40
		7	74	64	54	46	51	49	43	33	78	71	61	52	52	50	44	39	86	81	76	58	53	51	46	43
		10	78	68	57	53	60	59	52	38	82	75	65	58	61	58	51	42	90	87	80	63	60	57	50	44
1000	1000	2	60	49	45	25	17	15	12	17	63	57	50	32	22	21	20	26	73	65	61	41	29	31	33	37
		4	68	57	50	37	36	34	30	26	72	65	57	44	39	38	34	33	81	75	70	51	43	43	40	40
		7	75	64	55	47	51	50	44	34	79	72	62	53	53	51	45	39	88	83	77	59	54	52	47	43
		10	79	69	58	53	61	60	53	39	84	76	66	59	62	60	52	43	92	88	82	64	62	59	50	44

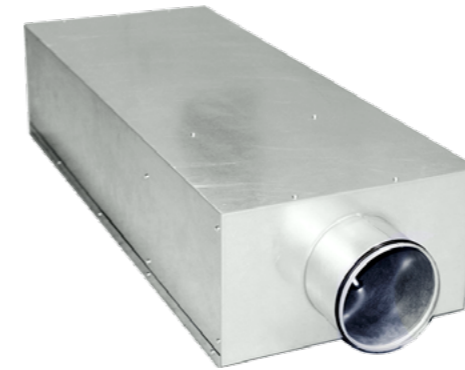

AIR TERMINAL UNIT - RVK

- Volume flow control regulation by a given set-point
- Factory parametrization in accordance with clients request
- High regulation precision
- RVK-A - supply air
- RVK-B - exhaust air
- Sound insulated case
- For high acoustic demand application

Options

- Constant
- Master-slave
- Insulated casing (50mm)
- MP-Bus (standard), LONWORKS, ModBus (Belimo/Siemens), KNX (Belimo/Siemens), MF (no Bus, Belimo), SGB (no Bus, Siemens), Bacnet (Siemens) (Siemens)

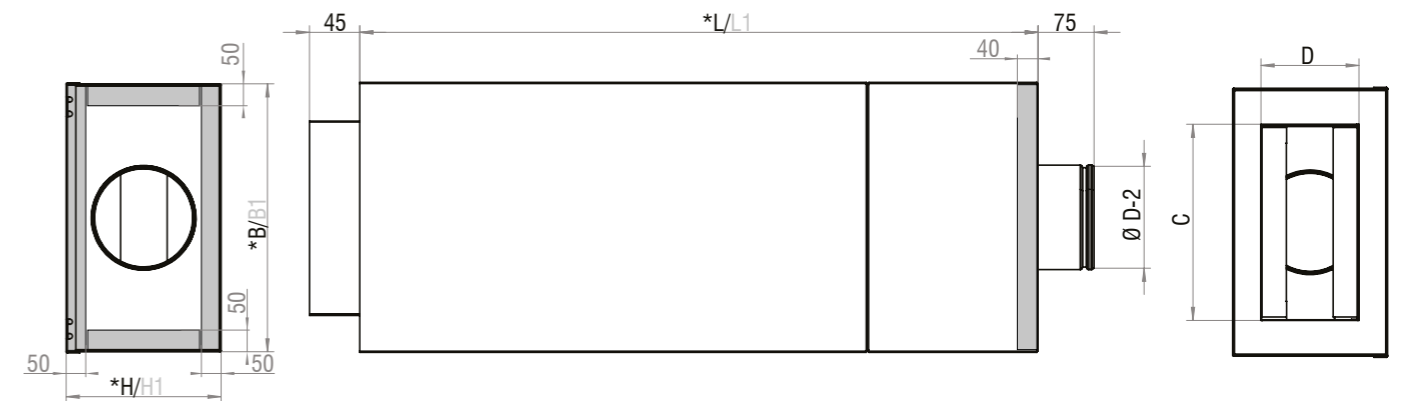

Dimensions:

RVK	ØD-2 [mm]	B [mm]	*B1 [mm]	H [mm]	*H1 [mm]	L [mm]	*L1 [mm]	C [mm]	D [mm]	V _{min} [m ³ /h]	V _{max} [m ³ /h]
125	123	300	400	236	336	1035	1075	200	150	54	540
160	158	410	510	236	336	1035	1075	300	150	90	900
200	198	560	660	281	381	1320	1360	460	200	145	1459
250	248	700	800	311	411	1440	1480	600	200	217	2215
315	313	900	1000	442	552	1440	1480	800	250	380	3680
400	398	1000	1100	525	625	1820	1860	900	350	615	6047

* B1, H1, L1 - dimensions of additionally insulated attenuator

Ordering key

Variable air volume control damper **RVK - A - ØDn - MP - Z - V - P - PZS**

- A** - Supply air
- B** - Exhaust air

Diameter

Communication type

- MP-Bus** (standard)
- LONWORKS**
- ModBus** (Belimo/Siemens)
- KNX** (Belimo/Siemens)
- MF** (no Bus, Belimo)
- SGB** (no Bus, Siemens)
- Bacnet** (Siemens)

Insulation

Volume flow V*min/max [m³/h]

Mode

- P** - single
- M** - master
- S** - slave
- K** - constant flow

Additional silencer

* if not otherwise specified, regulator is set to standard factory values V_{max} and V_{min} .

Air supply and exhaust

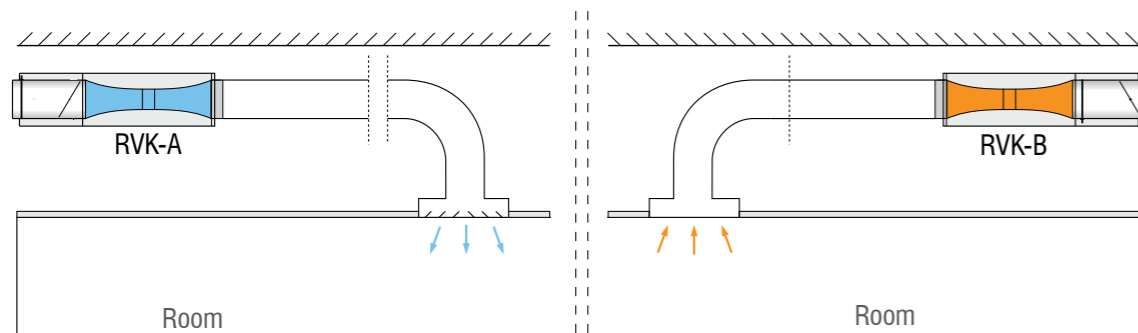

Sound power level RVK-A / RVK-A-Z

Size	Ø125					Ø160					Ø200					Ø250					Ø315					Ø400													
	V [m³/h]																																						
P _t = 125 Pa	L _w [dB(Okt)]	f _z [Hz]	63	50	49	47	54	56	50	51	52	55	63	33	39	46	51	59	36	41	47	52	60	35	43	49	57	65	35	43	51	66	72						
			125	26	33	44	50	51	33	42	52	54	59	29	38	43	45	54	34	38	42	45	52	36	41	46	47	54	35	42	48	53	63						
			250	18	26	35	41	49	24	31	39	49	51	23	28	33	37	46	20	24	28	36	44	28	33	37	38	49	28	31	34	43	45						
			500	15	17	18	25	36	15	18	21	30	38	15	15	16	27	38	15	16	17	33	40	15	16	16	25	37	15	19	22	36	42						
			1000	15	15	15	16	23	15	15	15	23	33	15	15	15	21	33	15	15	15	28	36	15	15	15	21	34	15	17	19	35	39						
			2000	15	15	15	15	15	15	18	21	15	27	15	15	15	15	28	15	15	15	24	33	15	15	15	15	31	15	15	17	30	39						
			4000	15	15	15	15	15	15	15	16	15	17	15	15	15	15	21	15	15	18	21	32	15	15	19	23	29	15	15	17	19	30	37					
			8000	16	15	15	15	15	15	15	16	15	16	17	16	15	15	15	15	15	15	25	33	15	20	25	34	34	15	19	23	35	41						
			L _w [dB(A)]		26 27 31 37 42 27 30 38 43 47 23 26 30 34 43 24 26 29 38 44 25 30 34 38 45 25 29 34 44 51																																		
P _t = 250 Pa	L _w [dB(Okt)]	f _z [Hz]	63	55	57	51	57	59	53	52	55	58	65	51	47	50	55	64	42	48	50	56	63	41	53	53	60	67	41	51	54	67	78						
			125	32	43	47	51	54	45	48	53	56	61	32	41	45	48	56	36	39	45	50	56	37	47	49	52	58	38	48	51	56	65						
			250	25	35	37	43	51	29	40	41	52	53	26	34	36	40	49	25	30	33	41	48	31	40	41	43	53	32	37	39	47	50						
			500	16	18	22	28	42	17	23	25	33	40	15	20	21	31	40	15	18	22	36	43	15	22	22	30	41	15	21	27	39	45						
			1000	15	15	15	19	37	15	15	15	25	35	15	15	15	23	35	15	15	15	31	39	15	15	15	26	37	15	18	24	37	42						
			2000	15	15	15	15	33	15	15	15	17	29	15	15	15	17	30	15	15	15	27	36	15	15	15	20	34	15	18	23	33	41						
			4000	15	15	15	15	19	15	15	19	17	21	15	15	15	15	24	15	15	15	24	34	15	15	15	27	34	15	20	26	34	41						
			8000	19	21	22	19	20	19	20	21	20	22	20	15	15	19	22	18	15	18	28	36	15	25	29	37	38	15	24	30	39	45						
			L _w [dB(A)]		30 34 34 39 46 32 36 39 45 49 28 30 32 37 46 26 28 32 40 47 27 35 37 42 49 27 35 38 47 55																																		
P _t = 500 Pa	L _w [dB(Okt)]	f _z [Hz]	63	56	60	53	58	62	55	54	56	60	66	42	55	58	64	46	49	55	59	66	49	52	61	65	72	41	55	58	69	78							
			125	31	41	46	58	60	37	49	54	60	66	33	44	49	53	57	40	44	50	57	60	38	51	58	60	65	43	53	56	61	67						
			250	25	36	41	47	55	29	41	45	52	56	29	37	41	47	50	28	37	41	46	52	35	45	49	51	54	37	49	50	52	57						
			500	16	23	26	32	38	20	28	34	37	44	19	28	30	34	44	15	26	29	37	46	23	27	33	39	47	24	29	34	40	50						
			1000	15	15	15	20	28	15	16	26	28	38	16	15	15	25	39	15	15	22	32	42	17	25	31	37	45	16	26	31	38	49						
			2000	15	15	15	15	20	15	15	23	20	33	15	15	15	18	34	15	15	20	28	39	15	22	29	35	42	15	26	30	36	46						
			4000	15	15	15	18	18	15	15	21	18	25	15	15	15	15	27	15	15	21	27	36	15	27	30	35	41	20	31	34	39	46						
			8000	22	23	22	28	29	19	23	23	27	31	23	22	25	28	31	20	18	26	31	39	22	34	37	42	45	25	35	38	44	50						
			L _w [dB(A)]		31 36 36 44 49 31 37 41 47 53 27 34 38 42 48 28 33 38 44 51 31 40 46 49 54 33 43 46 51 58																																		

Sound power level - RVK-B / RVK-B-Z

Size		ø125					ø160					ø200					ø250					ø315					ø400						
V [m³/h]		54	126	216	342	540	90	234	360	612	900	144	393	648	1008	1458	216	612	1008	1692	2214	378	954	1512	2592	3690	612	1602	2556	4500	6048		
P _i = 125 Pa	L _w [dB(Okt)]	f _{sr} [Hz]	63	50	50	49	51	-	43	42	42	43	-	42	45	49	53	-	42	47	51	47	-	43	50	56	57	-	43	48	52	68	-
			125	35	42	47	48	-	29	40	51	50	-	24	35	46	43	-	24	35	45	42	-	35	45	54	51	-	35	39	44	47	-
			250	26	29	33	38	-	24	30	38	41	-	18	24	29	35	-	20	24	29	30	-	25	32	38	41	-	22	26	30	36	-
			500	15	15	15	21	-	15	18	21	22	-	15	17	19	23	-	15	18	21	27	-	15	20	24	31	-	15	18	21	30	-
			1000	15	15	15	15	-	15	15	15	15	-	15	15	15	22	-	15	15	16	26	-	15	17	20	33	-	15	17	20	30	-
			2000	15	15	15	15	-	15	15	15	15	-	15	15	15	21	-	15	15	16	22	-	15	16	17	22	-	15	17	20	29	-
			4000	15	15	15	15	-	15	15	15	15	-	15	15	15	19	-	15	16	16	18	-	15	18	20	24	-	15	18	22	27	-
			8000	17	16	15	16	-	15	15	15	17	-	15	16	17	28	-	17	18	19	21	-	15	23	31	30	-	17	22	27	32	-
			Lw [dB(A)]		27	30	33	35	-	24	28	36	37	-	23	26	32	34	-	24	26	32	32	-	25	32	40	40	-	25	29	33	43
P _i = 250 Pa	L _w [dB(Okt)]	f _{sr} [Hz]	63	51	43	56	57	59	42	47	43	45	46	48	51	51	55	53	47	46	53	51	55	45	49	59	61	65	45	53	55	70	80
			125	39	45	48	51	49	30	49	53	54	49	29	38	46	46	44	29	41	47	47	45	37	50	55	55	49	37	43	48	52	62
			250	30	32	35	41	39	28	36	41	45	41	23	29	32	38	38	24	30	33	36	44	26	37	41	45	42	25	31	35	41	47
			500	17	16	18	25	28	17	23	26	28	31	20	20	23	27	35	19	22	25	31	38	15	22	29	36	43	18	21	26	35	44
			1000	15	15	15	16	25	15	15	15	17	26	15	15	19	25	35	15	17	20	28	34	15	20	25	31	40	16	20	24	34	41
			2000	15	15	15	15	18	15	15	15	15	19	15	15	18	23	32	15	16	20	25	35	15	15	21	26	36	15	19	24	33	42
			4000	15	15	15	15	15	15	15	15	17	16	15	15	18	23	28	15	17	20	23	31	15	17	25	30	36	16	23	27	34	43
			8000	20	19	15	20	22	18	18	18	23	21	17	18	23	31	32	21	22	24	27	33	17	20	33	35	38	22	26	32	38	47
			Lw [dB(A)]		29	31	35	38	38	25	35	38	40	37	26	29	33	37	40	26	30	34	36	43	26	36	42	44	47	27	33	37	46
P _i = 500 Pa	L _w [dB(Okt)]	f _{sr} [Hz]	63	54	53	54	56	60	57	44	45	49	56	46	50	56	60	64	46	49	56	61	62	49	66	65	71	72	47	56	61	70	80
			125	39	46	50	58	59	38	50	57	61	65	33	40	47	53	53	31	43	51	56	56	39	51	58	61	61	38	49	54	58	63
			250	27	36	39	48	49	26	41	47	51	51	26	31	36	44	46	28	35	40	45	47	28	39	45	50	52	30	39	42	47	50
			500	15	20	25	31	36	15	29	33	37	42	22	24	29	32	39	23	27	31	37	41	15	31	36	41	47	23	28	31	37	45
			1000	15	15	17	21	26	15	15	18	24	30	19	19	24	28	37	19	21	24	32	36	15	25	29	35	42	20	25	29	35	42
			2000	15	15	15	16	21	15	15	15	18	24	17	17	23	27	34	18	21	24	29	37	15	20	25	29	37	19	24	28	34	42
			4000	15	15	15	16	20	16	15	15	22	26	18	18	25	27	32	19	21	25	31	35	15	24	32	40	45	21	29	36	43	47
			8000	19	19	21	25	30	18	18	22	32	37	24	24	35	37	38	24	25	29	35	38	15	24	33	39	44	26	32	38	44	49
			Lw [dB(A)]		30	33	37	44	46	32	37	43	47	50	28	31	38	42	45	29	33	39	44	47	28	42	45	50	53	31	39	44	50

Case radiated noise - RVK-A

Size		ø125					ø160					ø200					ø250					ø315					ø400						
V [m³/h]		54	126	216	342	540	90	234	360	612	900	144	393	648	1008	1458	216	612	1008	1692	2214	378	954	1512	2592	3690	612	1602	2556	4500	6048		
P _i = 125 Pa	L _w [dB(Okt)]	f _{sr} [Hz]	63	15	25	35	41	45	22	29	36	46	48	30	36	42	48	53	25	38	50	50	55	34	42	49	55	61	37	45	52	62	76
			125	28	34	40	45	46	28	34	40	42	46	32	37	41	44	50	31	37	42	47	50	36	39	42	47	51	38	40	42	45	60
			250	26	30	33	39	43	23	29	35	40	46	29	33	37	43	51	29	32	35	37	47	27	32	36	42	49	32	35	37	39	52
			500	26	26	26	31	37	25	26	27	31	38	28	28	27	30	43	26	26	26	29	41	25	26	27	37	39	28	32	36	29	44
			1000	26	24	21	25	29	21	21	21	23	31	20	21	22	25	33	23	22	20	21	28	22	22	21	26	30	25	25	24	26	32
			2000	17	17	17	22	27	15	17	19	23	27	18	20	21	25	32	15	17	19	23	32	15	18	20	28	35	20	23	25	31	38
			4000	15	15	15	16	18	15	15	15	16	22	15	20	25	26	30	15	15	15	19	26	15	15	15	21	29	15	17	18	23	32
			8000	15	17	18	16	19	15	16	16	22	28	15	20	24	25	34	15	15	15	19	28	15	15	15	24	28	15	20	25	23	32
			Lw [dB(A)]		29	29	30	35	39	26	28	31	35	41	28	31	33	37	46	28	29	32	35	43	28	30	32	39	44	31	33	36	39
P _i = 250 Pa	L _w [dB(Okt)]	f _{sr} [Hz]	63	27	34	38	42	47	25	34	39	48	51	31	40	46	51	56	28	46	52	54	58	35	49	52	58	64	40	52	56	67	77
			125	31	40	42	46	49	28	38	42	45	49	32	42	44	47	53	33	42	46	51	54	36	44	46	51	55	40	45	47	52	62
			250	27	32	35	40	45	25	34	37	42	48	30	38	41	46	53	32	39	40	44	51	31	38	42	47	53	36	43	43	47	55
			500	26	30	30	33	40	26	30	31	35	42	29	32	33	36	46	30	32	33	37	45	29	33	34	42	44	33	35	35	39	48
			1000	27	27	27	29	34	24	26	27	29	35	25	28	29	31	38	27	28	29	31	35	26	29	29	33	36	30	30	32	34	37
			2000	20	21	23	26	31	18	22	25	28	32	21	24	27	30	36	21	24	26	30	36	20	24	27	33	39	26	28	32	37	41
			4000	15	15	16	21	25	15	15	19	23	28	18	21	27	28	35	15	17	21	27	32	15	20	24	29	35	19	23	27	32	37
			8000	15	16	20	21	25	16	22	22	27	32	22	25	29	30	38	15	19	23	28	34	15	15	20	30	34	15	15	30	30	36
			Lw [dB(A)]		30	32	33	37	42	28	32	35	38	44	31	35	38	41	49	32	35	37	41	47	31	36	38	44	49	35	39	41	46
P _i = 500 Pa	L _w [dB(Okt)]	f _{sr} [Hz]	63	20	29	38	46	51	21	35	44	49	55	27	45	49	55	60	36	47	53	58	62	40	50	56	61	68	44	57	59	67	79
			125	35	41	46	50	54	33	41	46	50	54	34	43	48	52	56	36	46	51	56	59	38	49	53	58	62	42	53	56	59	63
			250	28	36	40	43	46	28	37	41	46	51	34	41	46	50	54	35	44	47	51	55	38	46	50	55	57	42	52	55	55	58
			500	27	34	37	40	43	28	35	38	42	47	36	40	42	44	51	34														

Case radiated noise - RVK-B

Size		ø125					ø160					ø200					ø250					ø315					ø400						
V [m³/h]		54	126	216	342	540	90	234	360	612	900	144	393	648	1008	1458	216	612	1008	1692	2214	378	954	1512	2592	3690	612	1602	2556	4500	6048		
P _i = 125 Pa	L _w [dB/Okf]	f _s [Hz]	63	15	22	29	37	-	17	29	40	45	-	26	36	46	45	-	23	36	48	46	-	27	40	52	58	-	29	38	47	60	-
			125	22	31	40	43	-	24	33	42	45	-	31	38	45	44	-	32	40	47	45	-	31	37	42	48	-	28	33	37	46	-
			250	15	25	34	39	-	16	24	31	35	-	22	26	30	36	-	15	22	29	29	-	16	23	29	37	-	15	22	29	42	-
			500	16	22	27	32	-	15	20	25	30	-	15	19	23	28	-	15	18	21	25	-	15	20	24	31	-	15	21	26	34	-
			1000	15	19	22	26	-	15	18	20	25	-	15	18	21	25	-	15	15	15	26	-	15	20	24	31	-	15	22	28	33	-
			2000	15	20	24	28	-	15	19	23	27	-	15	20	24	29	-	15	21	26	32	-	16	23	29	34	-	15	25	34	37	-
			4000	15	19	23	27	-	15	18	21	25	-	15	18	21	26	-	15	17	19	24	-	15	19	23	30	-	15	23	31	36	-
			8000	15	21	26	28	-	15	19	22	29	-	15	17	19	29	-	15	21	26	26	-	16	22	27	33	-	15	22	29	38	-
			Lw [dB(A)]		22	27	33	37	-	22	26	31	36	-	23	28	33	36	-	23	28	34	36	-	23	29	35	41	-	22	30	38	44
P _i = 250 Pa	L _w [dB/Okf]	f _s [Hz]	63	15	24	34	40	45	23	36	42	47	48	32	42	47	48	48	25	43	50	50	50	28	47	54	60	64	32	45	50	63	52
			125	26	36	41	45	48	29	39	43	47	50	34	41	46	48	46	32	45	48	48	45	31	40	44	50	54	30	37	42	50	48
			250	18	29	35	40	43	20	29	34	38	42	24	30	34	39	42	15	29	33	38	47	15	29	34	42	48	20	32	36	47	71
			500	15	22	30	35	40	15	24	28	33	38	18	24	28	32	39	15	21	27	33	40	16	25	30	36	43	20	28	33	40	58
			1000	15	21	26	29	32	15	21	24	28	32	17	22	26	29	32	15	15	16	31	32	15	25	29	35	38	22	28	33	38	50
			2000	19	22	28	32	34	15	22	27	31	33	19	22	28	32	33	15	24	30	34	32	15	28	33	38	40	22	32	38	41	47
			4000	15	22	27	31	31	15	20	25	29	32	16	21	26	31	31	15	17	25	29	26	15	23	28	34	37	19	30	36	41	44
			8000	20	26	30	32	33	19	24	27	32	34	20	23	26	33	32	15	20	30	31	29	15	26	31	37	39	18	28	34	42	42
			Lw [dB(A)]		25	31	36	40	42	23	30	35	39	42	26	31	36	40	42	23	32	37	40	42	23	34	39	44	48	28	37	43	48
P _i = 500 Pa	L _w [dB/Okf]	f _s [Hz]	63	27	38	42	45	48	24	36	42	49	55	22	42	51	55	61	32	47	56	59	59	39	50	55	60	62	44	51	56	64	45
			125	24	38	45	50	53	28	39	45	51	56	31	43	48	52	53	33	45	52	55	56	34	44	48	53	55	35	43	49	52	41
			250	24	32	37	42	46	22	32	37	42	47	25	34	39	45	48	15	33	39	45	50	19	37	43	48	52	30	42	46	49	72
			500	23	29	32	35	41	20	27	31	37	42	22	29	33	37	44	15	29	34	41	44	18	32	38	42	46	26	36	39	44	58
			1000	23	27	29	32	35	20	26	29	33	36	20	26	30	34	38	18	27	31	37	41	24	31	35	40	43	28	34	37	43	53
			2000	23	29	33	36	38	22	28	32	36	39	21	26	32	36	39	18	29	34	38	41	25	34	38	42	44	32	38	40	45	48
			4000	22	28	30	33	38	20	26	30	34	39	19	26	32	38	44	15	26	33	39	43	20	33	38	44	45	29	40	43	49	46
			8000	25	30	32	34	37	24	28	31	36	40	23	28	34	38	43	15	24	33	37	40	20	31	37	42	44	28	39	40	47	47
			Lw [dB(A)]		30	36	39	42	46	29	35	39	43	48	28	35	40	45	50	25	36	42	47	50	30	40	45	50	52	37	45	48	54

Case radiated noise - RVK-A-Z

Size		ø125					ø160					ø200					ø250					ø315					ø400											
V [m³/h]		54	126	216	342	540	90	234	360	612	900	144	393	648	1008	1458	216	612	1008	1692	2214	378	954	1512	2592	3690	612	1602	2556	4500	6048							
P _i = 125 Pa	L _w [dB/Okf]	f _s [Hz]	63	16	25	33	39	43	15	25	34	44	46	23	32	40	46	51	23	36	48	48	53	31	39	46	52	58	36	43	50	58	70					
			125	19	25	31	36	37	20	27	34	36	40	28	33	38	41	47	26	32	37	42	45	30	33	36	41	45	32	34	36	39	54					
			250	19	23	26	32	36	17	23	29	34	40	21	26	30	36	44	21	24	27	29	39	18	23	27	33	40	22	25	27	29	42					
			500	16	16	16	21	27	16	17	18	22	29	17	17	16	19	32	18	17	16	19	31	15	16	16	26	28	16	16	15	17	32					
			1000	15	15	15	15	17	15	15	15	15	18	15	15	15	15	19	15	15	15	15	16	15	15	15	15	15	15	15	15	19	16	16	15	17	23	
			2000	15	15	15	15	15	15	15	15	15	15	15	15	15	15	15	15	15	15	15	15	15	15	15	15	15	15	15	15	15	15	15	15	15	24	
			4000	15	15	15	15	15	15	15	15	15	15	15	15	15	15	15	15	15	15	15	15	15	15	15	15	15	15	15	15	15	15	15	15	15	24	
			8000	15	15	15	15	15	15	15	15	15	15	15	15	15	15	15	15	15	15	15	15	15	15	15	15	15	15	15	15	15	15	15	15	15	15	24
			Lw [dB(A)]		22	23	24	27	30	22	23	25	29	34	23	24	27	31	38	23	24	27	29	35	23	24	26	31	37	24	25	28	33	45				
P _i = 250 Pa	L _w [dB/Okf]	f _s [Hz]	63	25	32	36	40	45	23	32	37	46	49	29	38	44	49	54	26	44	50	52	56	32	44	49	55	61	38	49	53	64	74					
			125	22	31	33	37	40	22	32	36	39	43	29	39	41	44	50	28	37	41	46	49	30	38	40	45	49	34	39	41	46	56					
			250	20	25	28	33	38	19	28	31	36	42	23	31	34	39	46	24	31	32	36	43	22	29	33	38	44	26	33	33	37	45					
			500	16	20	20	23	15	17	21	22	26	33	19	21	22	25	35	21	22	23	27	35	18	22	23	31	33	21	23	23	27	36					
			1000	15	15	15	17	22	15	15	15	16	22	15	15	15	17	24	16	16	17	19	23	15	18	18	22	25	21	21	23	25	28					
			2000	15	15	15	15	18	15	15	15	16	20	15	15	15	17	23	15	15	15	18	24	15	15	15	16	22	28	17	19	23	28	32				
			4000	15	15	15	15	15	15	15	15	15	15	15	15	15	15	15	15	15	15	15	15	15	15	15	15	15	15	15	15	15	15	15	15	29		
			8000	15	15	15	15	15	15	15	15	15	15	15	15	15	15	15	15	15	15	15	15	15	15	15	15	15	15	15	15	15	15	15	15	15	28	
			Lw [dB(A)]		22	24	25	28	32	22	25	27	31	36	24	28	30	34	40	24	28	30	34	39	23	27	30	36	40	27	30	33	40	49				
P _i = 500 Pa	L _w [dB/Okf]	f _s [Hz]	63	18	27	36	44	49	19	33	42	47	53	25	43	47	53	58	34	45	51	56	60	37	47	53	58	65	41	54	56	64	76					
			125	26	32	37	41	45	27	35	40	44	48	31	40	45	49	53	31	41	46	51	54	32	43	47	52	56	36	47	50	53	57					
			250	21	29	33	36	39	22	31	35	40	45	27	34	39	43	47	27	36	39	43	47	29	37	41	46											

Case radiated noise - RVK-B-Z

Size		ø125					ø160					ø200					ø250					ø315					ø400						
V [m³/h]		54	126	216	342	540	90	234	360	612	900	144	393	648	1008	1458	216	612	1008	1692	2214	378	954	1512	2592	3690	612	1602	2556	4500	6048		
P _i = 125 Pa	L _w [dB/Okf]	f _s [Hz]	63	15	23	31	38	-	21	31	40	45	-	30	38	45	46	-	22	35	48	48	-	28	41	53	59	-	31	40	48	61	-
			125	19	27	35	40	-	23	30	37	41	-	29	35	41	43	-	26	35	43	44	-	27	34	40	46	-	26	32	37	45	-
			250	15	22	29	35	-	15	22	29	33	-	20	25	29	35	-	15	22	28	32	-	15	23	30	38	-	16	24	31	42	-
			500	15	19	23	29	-	15	19	22	27	-	15	19	22	27	-	15	18	21	26	-	15	20	25	31	-	15	21	27	32	-
			1000	15	19	22	26	-	15	18	20	24	-	15	18	21	25	-	15	15	15	27	-	15	20	25	31	-	18	24	29	33	-
			2000	15	19	23	27	-	15	19	22	26	-	15	19	22	27	-	15	20	24	30	-	15	21	27	32	-	15	23	31	34	-
			4000	15	19	22	26	-	15	18	20	24	-	15	18	20	26	-	15	17	19	25	-	15	19	22	28	-	15	23	30	35	-
			8000	15	20	25	27	-	15	19	22	27	-	15	18	20	28	-	15	20	25	27	-	15	21	26	32	-	15	22	28	36	-
L _w [dB(A)]		22	26	31	35	-	22	26	29	34	-	23	27	30	35	-	22	26	32	36	-	22	28	34	40	-	23	30	37	43	-		
P _i = 250 Pa	L _w [dB/Okf]	f _s [Hz]	63	15	21	31	37	42	21	34	40	45	46	30	40	45	46	46	23	41	48	48	48	27	46	53	59	63	31	44	49	62	70
			125	20	30	35	39	42	23	33	37	41	44	29	36	41	43	41	27	40	43	43	40	27	36	40	46	50	26	33	38	46	54
			250	15	23	29	34	37	15	24	29	33	37	20	29	30	35	38	15	25	29	34	43	15	25	30	38	44	16	28	32	43	46
			500	15	15	23	28	33	15	18	22	27	32	15	19	23	27	34	15	16	22	28	35	15	20	25	31	38	15	23	28	35	42
			1000	15	17	22	25	28	15	17	20	24	28	15	18	22	25	28	15	15	15	27	28	15	21	25	31	34	18	24	29	34	40
			2000	15	17	23	27	29	15	17	22	26	15	15	17	23	27	28	15	19	25	29	27	15	22	27	32	34	15	25	31	34	35
			4000	15	17	22	26	26	15	15	20	24	27	15	16	21	26	26	15	15	20	24	21	15	17	22	28	31	15	24	30	35	37
			8000	15	21	25	27	28	15	19	22	27	29	15	18	21	28	27	15	15	25	26	24	15	21	26	32	34	15	23	29	37	41
L _w [dB(A)]		22	25	31	34	37	22	25	29	34	36	23	27	31	35	37	22	27	32	35	38	22	29	34	40	44	23	32	37	44	49		
P _i = 500 Pa	L _w [dB/Okf]	f _s [Hz]	63	24	35	39	42	45	22	34	40	47	53	20	40	49	53	59	38	45	54	57	57	38	49	54	59	61	43	50	55	63	71
			125	18	32	39	44	47	22	33	39	45	50	26	38	43	47	48	28	40	47	50	51	30	40	44	49	51	31	39	45	48	54
			250	18	26	31	36	40	17	27	32	37	42	21	30	35	41	44	15	29	35	41	46	15	33	39	44	48	26	38	42	45	49
			500	16	22	25	28	34	15	21	25	31	36	17	24	28	32	39	15	24	29	36	39	15	27	33	37	41	21	31	34	39	43
			1000	19	23	25	28	31	16	22	25	29	32	16	22	26	30	34	15	23	27	33	37	20	27	31	36	39	24	30	33	39	42
			2000	18	24	28	31	33	17	23	27	31	34	16	21	27	31	34	15	24	29	33	36	19	28	32	36	38	25	31	33	38	40
			4000	17	23	25	28	33	15	21	25	29	34	15	21	27	33	39	15	21	28	34	38	15	28	32	38	39	23	34	37	43	45
			8000	20	25	27	29	32	19	23	26	31	35	18	23	29	33	38	15	19	28	32	35	15	27	32	37	39	23	34	35	42	45
L _w [dB(A)]		25	31	34	37	41	24	30	34	38	42	24	30	36	40	45	23	31	37	42	45	25	35	40	45	47	31	40	43	48	52		

ADDITIONAL ATTENUATOR PZS

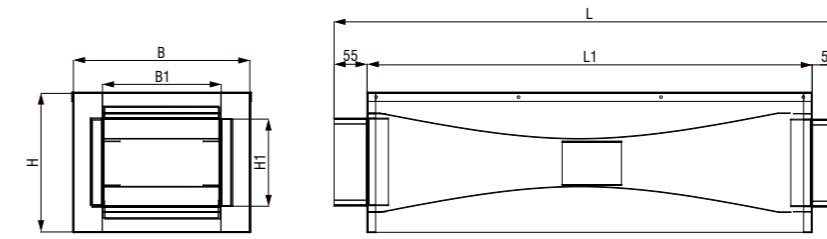

Size	L	L1	H	H1	B	B1
ø125	862	750	236	150	300	200
ø160	862	750	236	150	410	300
ø200	1012	900	281	200	560	460
ø250	1012	900	311	200	700	600
ø315	1112	1000	361	250	900	800
ø400	1362	1250	446	350	1000	900

Sound power levels with additional attenuator

Size		ø125					ø160					ø200					ø250					ø315					ø400						
V [m³/h]		54	126	216	342	540	90	234	360	612	900	144	393	648	1008	1458	216	612	1008	1692	2214	378	954	1512	2592	3690	612	1602	2556	4500	6048		
P _i = 125 Pa	L _w [dB/Okf]	f _s [Hz]	63	49	47	45	51	52	48	49	50	52	60	34	39	44	49	58	34	40	45	50	58	33	40	47	55	63	32	41	49	64	73
			125	22	31	40	45	48	27	38	48	50	55	25	32	39	41	50	30	34	38	41	48	32	37	42	43	50	31	38	44	49	59
			250	15	23	30	36	44	17	25	32	43	44	15	20	25	29	39	15	17	18	26	34	19	24	28	29	40	19	22	25	34	36
			500	15	15	15	15	26	15	15	15	17	23	15	15	15	18	27	15	15	15	20	27	15	15	15	15	24	15	15	15	27	32
			1000	15	15	15	15	21	15	15	15	15	18	15	15	15	15	17	15	15	15	15	23	15	15	15	15	24	15	15	15	25	29
			2000	15	15	15	15	17	15	15	15	15	15	15	15	15	15	15	15	15	15	15	18	15	15	15	16	19	15	15	15	20	29
			4000	15	15	15	15	15	15	15	15	15	15	15	15	15	15	15	15	15	15	15	18	15	15	15	15	19	15	15	15	23	30
			8000	15	15	15	15	15	15	15	15	15	15	15	15	15	15	15	15	15	15	15	17	25	15	17	19	28	28	15	17	19	31
L _w [dB(A)]		25	25	28	33	38	25	27	33	38	41	22	24	27	29	37	23	24	26	29	36	23	25	29	33	40	23	26	30	40	49		
P _i = 250 Pa	L _w [dB/Okf]	f _s [Hz]	63	53	55	49	54	57	51	50	53	55	63	49	45	48	53	61	40	46	48	54	61	39	51	51	58	65	39	49	52	65	76
			125	29	39	43	47	50	41	44	49	52	57	28	37	41	44	52	32	35	41	46	52	33	43	45	48	54	34	44	47	52	61
			250	21	30	32	38	46	22	33	34	45	46	18	26	28	32	41	16	21	23	31	38	22	31	32	34	44	23	28	30	38	41
			500	15	15	16	16	27	15	15	15	19	25	15	15	15	21	29	15	15	15	22	28	15	15	15	18	28	15	15	18	29	35
			1000	15	15	15	15	22	15	15	15	15	20	15	15	15	15	21	15	15	15	17	24	15	15	15	15	25	15	15	15	27	32
			2000	15	15	15	15	19	15	15	15	15	16	15	15	15	15	15	15	15	15	15	21	15	15	15	15	22	15	15	15	23	31
			4000	15	15	15	15	15	15	15	15	15	15	15	15	15	15	15	15	15	15	15	15	15	15	15	15	15	15	15	15	20	23
			8000	15	15	15	15	15	15	15	15	15	15	15	15	15	15	15	15	15	15	15	15	15	15	15	15	15	15	15	15	15	15
L _w [dB(A)]		28	31	30	35	40	29	31	35	40	44	26	26	28	32	40	23	25	28	33	40	24	31	32	37	43	24	30	34	42	52		
P _i = 500 Pa	L _w [dB/Okf]	f _s [Hz]	63	54	58	51	55	58	53	52	54	58	64	40	53	56	56	62															

Case radiated noise with additional attenuator RVK-B/RVK-B-Z + PZS

Size		ø125					ø160					ø200					ø250					ø315					ø400						
V [m³/h]		54	126	216	342	540	90	234	360	612	900	144	393	648	1008	1458	216	612	1008	1692	2214	378	954	1512	2592	3690	612	1602	2556	4500	6048		
ρ _i = 125 Pa	L _w [dB(Okt)]	f _z [Hz]	63	46	48	50	48	-	32	36	40	41	-	40	44	47	51	-	38	44	49	45	-	41	48	54	55	-	41	46	50	65	-
			125	32	38	43	44	-	26	37	47	46	-	21	31	41	39	-	20	31	42	38	-	31	41	50	47	-	31	36	40	43	-
			250	22	25	28	33	-	18	25	31	34	-	15	19	22	30	-	15	19	22	32	-	17	24	30	36	-	15	20	24	34	-
			500	15	15	15	19	-	15	15	15	18	-	15	15	15	25	-	15	16	16	28	-	15	16	17	31	-	15	16	17	30	-
			1000	15	15	15	15	-	15	15	15	15	-	15	15	15	17	-	15	15	15	22	-	15	15	15	29	-	15	15	15	27	-
			2000	15	15	15	15	-	15	15	15	15	-	15	15	15	15	-	15	15	15	19	-	15	15	15	22	-	15	15	15	16	-
			4000	15	15	15	15	-	15	15	15	15	-	15	15	15	15	-	15	15	15	15	-	15	15	15	15	-	15	15	15	20	-
			8000	15	15	15	15	-	15	15	15	15	-	15	15	15	16	-	15	15	15	15	-	15	20	25	24	-	15	19	23	28	-
	Lw [dB(A)]		25	22	30	31	-	22	22	32	32	-	23	22	28	30	-	22	22	29	30	-	23	23	36	36	-	23	23	29	40	-	
ρ _i = 250 Pa	L _w [dB(Okt)]	f _z [Hz]	63	49	52	54	55	57	40	41	41	43	44	46	48	49	53	51	45	48	51	49	53	43	50	57	59	63	43	48	53	68	78
			125	35	40	44	47	45	27	38	49	50	45	26	34	42	42	42	25	34	43	43	44	33	42	51	51	47	33	39	44	48	58
			250	25	28	30	36	36	22	28	34	38	36	17	21	25	32	38	16	21	25	35	43	18	26	33	39	45	17	23	28	38	45
			500	15	16	16	22	32	15	15	15	21	31	15	15	15	26	38	15	17	18	33	42	15	18	21	35	44	15	18	20	34	43
			1000	15	15	15	17	29	15	15	15	15	26	15	15	15	20	33	15	15	15	28	38	15	16	16	30	41	15	15	15	29	39
			2000	15	15	15	15	22	15	15	15	15	19	15	15	15	15	27	15	15	15	21	32	15	15	15	23	36	15	15	15	25	35
			4000	15	15	15	15	15	15	15	15	15	15	15	15	15	15	18	15	15	15	15	24	15	15	15	20	29	15	18	20	27	36
			8000	15	15	15	15	15	15	15	15	18	16	15	15	15	18	19	15	16	17	20	25	15	21	27	29	32	19	24	28	34	43
	Lw [dB(A)]		27	23	32	34	36	23	23	34	36	34	24	22	29	32	39	24	22	30	35	43	24	24	37	40	46	25	25	33	44	53	
ρ _i = 500 Pa	L _w [dB(Okt)]	f _z [Hz]	63	52	52	52	54	58	55	49	43	47	54	44	49	54	58	62	44	49	54	59	60	47	55	63	69	70	45	52	59	68	78
			125	35	41	46	54	55	34	44	53	57	61	29	36	43	49	49	27	37	47	52	52	35	45	54	57	57	34	42	50	54	59
			250	23	29	34	43	44	20	30	40	44	44	19	24	28	37	41	19	25	30	38	43	20	28	36	42	47	21	27	33	40	46
			500	15	16	16	22	32	15	17	19	24	32	15	17	19	27	38	15	18	20	33	42	15	20	25	35	45	15	19	23	34	43
			1000	15	15	15	17	29	15	15	15	15	27	15	15	15	20	34	15	15	15	28	38	15	17	18	31	41	15	18	20	30	39
			2000	15	15	15	15	22	15	15	15	15	20	15	15	15	15	27	15	15	15	21	32	15	15	15	24	36	15	17	19	25	35
			4000	15	15	15	15	15	15	15	15	15	15	15	15	15	15	18	15	15	15	17	25	15	18	21	29	35	15	22	29	36	40
			8000	15	15	15	18	22	15	16	17	26	31	15	18	21	23	24	17	19	21	27	30	15	21	27	33	38	22	28	34	40	45
	Lw [dB(A)]		28	23	33	40	42	30	23	38	42	46	24	23	32	37	41	24	23	33	39	44	26	25	41	46	49	26	29	39	46	54	

VOLUME FLOW CALCULATION RELATED TO CONTROL SIGNAL

In mode W1: 0...10VDC control signal Y corresponds to following volumes: $\dot{V}_{act} = \dot{V}_{min} + \frac{Y}{10VDC} \cdot (\dot{V}_{max} - \dot{V}_{min})$

and volumes correspond Y = 0VDC for V_{min} and Y = 10VDC for V_{max} according to: $Y = 10VDC \cdot \frac{\dot{V}_{act} - \dot{V}_{min}}{\dot{V}_{max} - \dot{V}_{min}}$

Notice: Y = 0VDC corresponds V_{min} and 10VDC corresponds V_{max}

In mode W2: 2...10VDC control signal Y corresponds to following volumes: $\dot{V}_{act} = \dot{V}_{min} + \frac{Y-2VDC}{8VDC} \cdot (\dot{V}_{max} - \dot{V}_{min})$

and volumes correspond Y = 2VDC for V_{min} and Y = 10VDC for V_{max} according to: $Y = 2VDC + 8VDC \cdot \frac{\dot{V}_{act} - \dot{V}_{min}}{\dot{V}_{max} - \dot{V}_{min}}$

with shutdown function for Y = 0VDC

Notice: Y = 2VDC corresponds V_{min} and 10VDC corresponds V_{max}

In mode W1 (0...10VDC) output signal U corresponds to following volumes: $U = 10VDC \cdot \frac{\dot{V}_{act}}{\dot{V}_{nom}}$

for actual volume calculation V_{act} form analog output signal U in mode W1: $V_{act} = V_{nom} \cdot \frac{U}{10VDC}$

In mode W (2...10VDC) output signal U corresponds to following volumes: $U = 2VDC + 8VDC \cdot \frac{\dot{V}_{act}}{\dot{V}_{nom}}$

for actual volume calculation V_{act} form analog output signal U in mode W (2...10VDC): $V_{act} = V_{nom} \cdot \frac{U-2VDC}{8VDC}$

WIRING DIAGRAM

Analog control signal

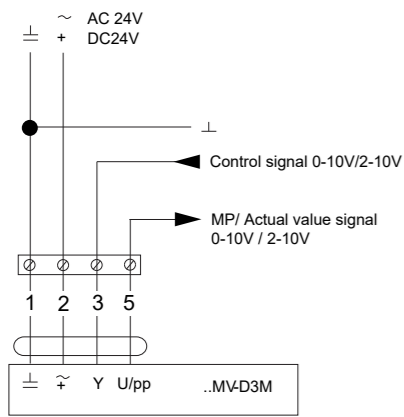

Analog control signal supply/extract in paralel mode

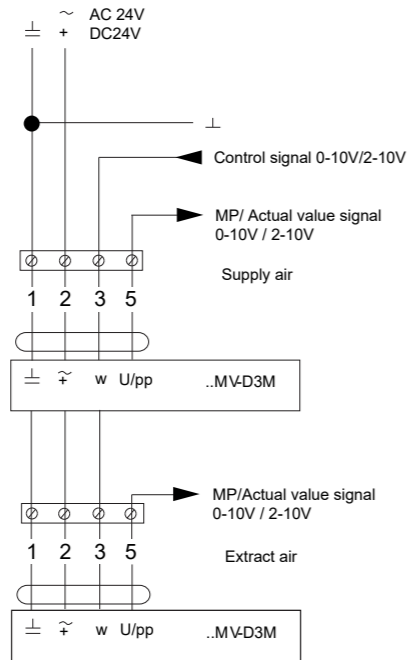

Analog control signal master / slave mode

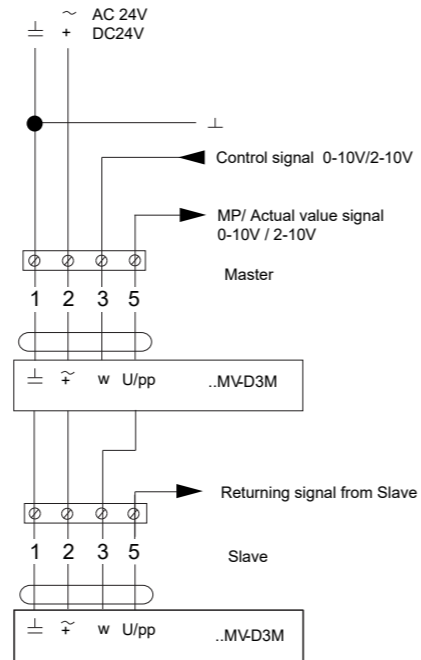

Mode	-	0...10V	0...10V	0...10V	0...10V
	2...10V	2...10V	2...10V	2...10V	2...10V
Signal					
Function	3	3	3	3	3
Damper CLOSED	a) CLOSED		c) CLOSED*		
V _{min} ...V _{max}		b) VAV			
CAV-V _{min}	All open - V _{min} active**				
Damper OPEN					e) OPEN*
CAV- V _{max}				d) V _{max}	

Contact closed, function active
 Contact open
 Contact closed, function active, only in 2..10V mode
 * Not available in DC 24V version
 **Damper is shut-off at 0,5V

**Constant mode:
- Standard 0,1V closing**

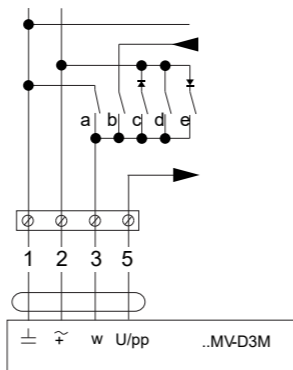

MOTOR DRIVE

- motor drives : Belimo (MP, LON, MOD, MF), Siemens (KNX)
- power supply - AC 24V, 50/60 Hz
- DC 24V
- diagnostic socket for service and PC-Tool software

Version

Type	Torque	Energy consumption	Dimensioning	Weight
LMV-D3-MP	5Nm	2W	4VA (max- 8A @ 5ms)	≈ 500g
NMW-D3-MP	10Nm	3W	5VA (max- 8A @ 5ms)	≈ 700g

Control variables	
V _{nom}	specific nominal volume flow, suitable for VAV units
Δp @ V _{nom}	50...450 Pa
V _{max}	20...100%
V _{min}	0...100%
V _{mid}	50% od V _{min} do V _{max}

Classic control	
VAV mod for referent variables Y (connection 3)	- DC 2...10V / (4...20mA with 500Ω impedance) - DC 0...10V / (0...20mA with 500Ω impedance) - Adjustable DC 0...10V } input impedance min. 100 kOhm
Actual signal value mod U5 (connection 5)	- DC 2...10V - DC 0...10V - Adjustable : volume flow, damper position or differential pressure } max. 0.5 mA
CAV mode (constant volume flow)	CLOSED / V _{min} / V _{mid} / V _{max} / OPEN* (*only with AC 24V supply)

Actuator	
Connection	Cable, 4 x 0,75 mm ²
Protection	
Safety class	III Safety extra - low voltage
Level of protection	IP54
Electromagnetic compliance	CE according to 89/336/EEC
Mode	Type 1 (according to EN 60730-1)
Rated power	0,5kV (according to EN 60730-1)
Operating temperature	0...+50°C
Non operating temperature	-20...+80°C
Relative humidity	5...95% r.h., no condensation (according to EN 60730-1)
Maintainance	Not required

MOTOR DRIVE

- motor drives : Siemens (KNX, MOD, SGB)
- power supply - AC 24 V \pm 20% 50/60 Hz
- Power consumption at
Actuator holds 1 VA/0.5 W
Actuator rotates 3 VA/2.5W

Damper actuator	
Normal torque	5 Nm (GDB) / 10 Nm (GLB)
Maximum torque	<7 Nm (GDB) / <14 Nm (GLB)
Normal rotation angle / maximum rotation angle	90° / 95° \pm 2°
Running time for normal rotation angle 90°	150 s (50Hz) / 125 s (60Hz)
Direction of rotation (Adjustable with e.g. ACS941)	Clockwise / Counterclockwise

Signal inputs	
Input voltage	DC 0/2 ... 10 V
Max. perm input volume	DC 35 V
Contact Sensing	
Contact open	DC 30 V contact voltage
Contact closed	DC 0 V, 8 mA contact current

Signal outputs	
Output voltage	DC 0/2 ... 10 V limited to DC 12 V
Max. output current	DC \pm 1 mA
Time constant (actual value U)	0,05...5 s
Resolution 0.01 S / factory settin 1 s	

Configurartion and maintenance interface	
Series A - D	6-pin, grid 2.54 mm
Series E or later	7-pin, grid 2.00 mm

Connection cable	
Cable lenght	0.9 m
Number of cores and cross-sectional area	6 x 0.75 mm ²

Degree of protection and safety class	
Degree of protection acc. to EN 60529 (cf. mounting instructions)	IP54
Safety class acc. to EN 60730	6 x 0.75 mm ²

Enviromental conditions	
Operation / transport	IEC 721-3-3 / IEC 721-3-2
Temperature	0 ... 50°C / -25...70°C
Humidity (non-condensing)	<95% r.h. / <95% r.h.

Standards and Regulations		
Product safety - Automatic electric controls for household and similar use	EN 60730-2-14 (mode of action type 1)	
Electromagnetic compatibility (application)	For residential, commercial and industrial enviroments	
EU conformity (CE)	GDB181.1E/3	GLB181.1E/3
	A5W00003842	A5W0000176
RCM Conformity	GDB181.1E/3	GLB181.1E/3
	A5W00003843	A5W0000177
Product enviromental declaration	CM2E4634E	

Air volume controller	
3-position controller with hysteresis	
V_{max}	20 ... 100%
V_{min}	-20 ... 100%
V_{mid}	0 ... 100%
V_n	1...3.16

Differential pressure sensor	
Connection tubes (inerior diameter)	3 ... 8 mm
Measuring range	0 ... 500 Pa
Operation range	0 ... 300 Pa
Precision at 23°C, 966 mbar and optional mounting position	
Zero point	\pm 0.2 Pa
Amplitude	\pm 4.5 of the measured value
Drift	\pm 0.1 Pa / Year
Max. permissible operation pressure	3000 Pa
Max. permissible overload on one side	3000 Pa

RVP-P-T

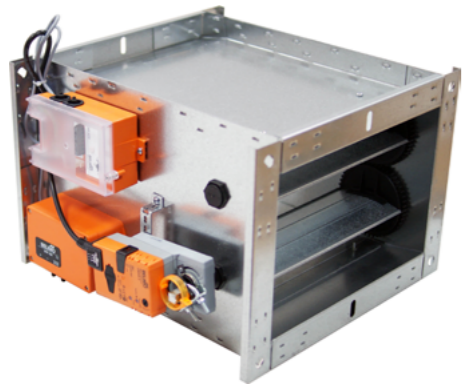

RVP-T

- Maintains constant overpressure or underpressure in duct or room
- Linear pressure regulation (not a function of volume flow)
- Adjusting set-point with potentiometer
- Regulation range 7,5 Pa - 600 Pa

Standard dimensions RVP-P-T [mm]

B	200 - 1000 mm, in increments 100 mm
H	100 - 1000 mm, in increments 100 mm

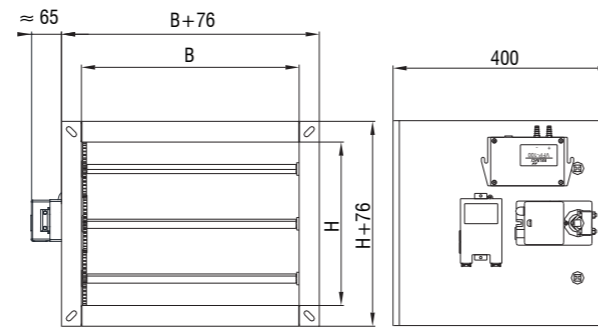
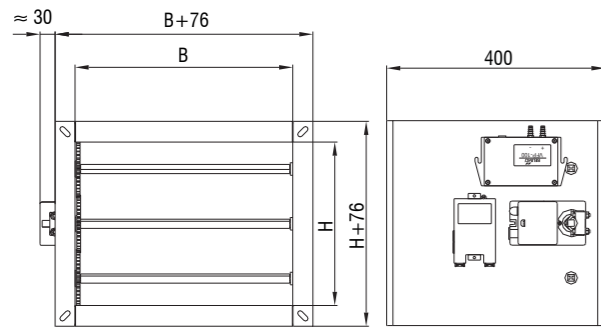

RVP-C-T



Standard dimensions RVP-C-T [mm]

øDn	100	125	160	200	250	315	400	500
L	400	400	400	400	500	600	600	750
øD _z	198	223	258	298	348	413	498	598
L _z	330	330	330	330	430	530	530	680

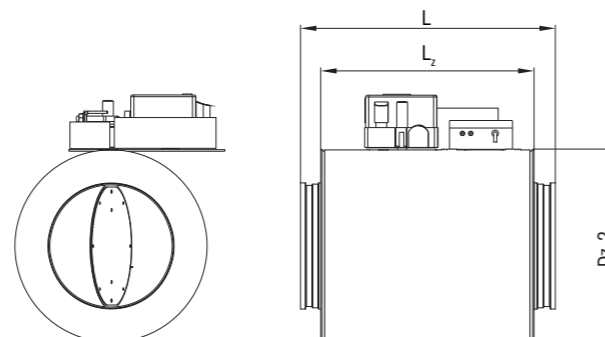
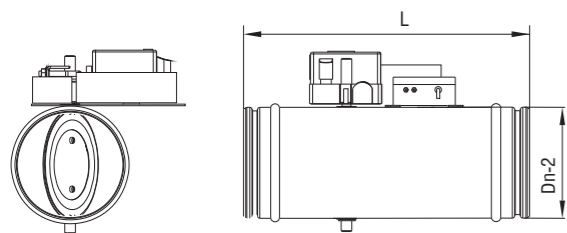

Operation principle

Example

If we want to maintain overpressure in room, + tube should be drawn from sensor to room, and - tube to referent area (hallway, ceiling etc.)

Example

If we want to maintain underpressure in room, - tube should be drawn from sensor to room, and + tube to referent area (hallway, ceiling etc.)

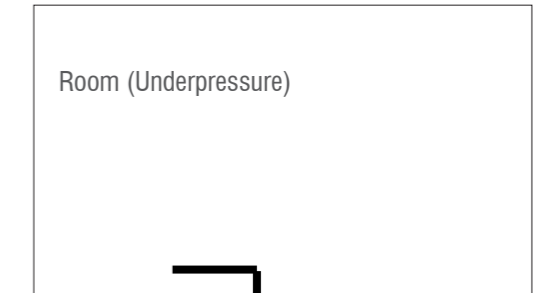
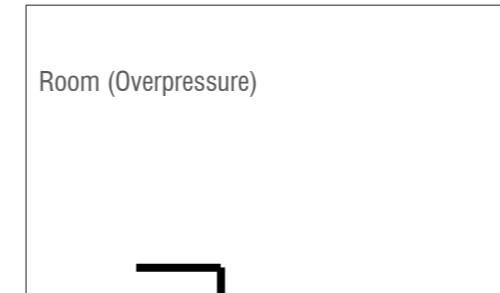

* same can be applied to duct distribution



Ordering key

Variable air volume control damper **RVP - C - T - 100 - ØDn - Z**

C - round version
P - rectangular version

Pressure controller

100 - 100 Pa
300 - 300 Pa
600 - 600 Pa
PP - Compact controller (0...300Pa)

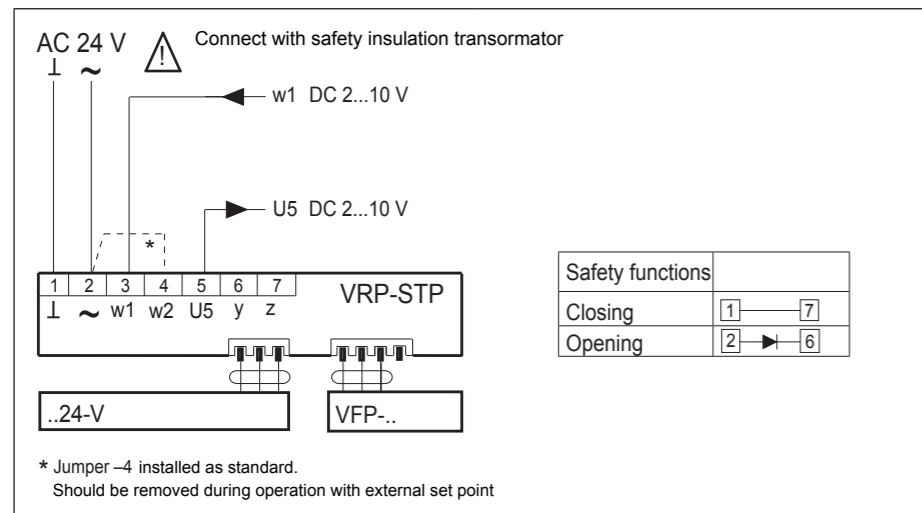

Motor drive and pressure sensor are delivered connected to regulator VRP-STP. During commissioning it is only necessary to bring power supply 24V AC to clamps 1 and 2 on regulator VRP-STP (under the transparent cover) and regulator is ready for operation. Connecting tubes are not delivered.

Technical specification:

Rated voltage	AC 4 V 50/60 Hz
Voltage range	AC 19...8.8 V
Power	1.3 W (incl. Sensor VFP-..., no damper drive ..-4-V)
Cable dimensioning	2,6 VA (incl. Sensor VFP-..., no damper drive ..-4-V)
Referent signal w1	DC ...10 V @ input impedance 100 kΩ
Actual signal value U5	DC ...10 V @ max. 0,5 mA (linear signal = 0...100% Δp)

Adjusting	
• Referent value	5...100% referent sensor signal (Factory setting = 100%. in example VFP-300: 100% = 300 Pa)
• Setpoint	30...100% referent value (Δp)

Connection	clamps for 2×1.5mm
Protection class	III (safety extra-low voltage) IP4
Operating temperature	0...+50 °C
Storage temperature	-0...+80 °C
Humidity test	to EN 60335-1
EMC	CE according to 004/108/EC

Operation specification:

Rated voltage	DC 15 V (from regulator VRP...)
Voltage range	DC 13,5...16,5 V
Mesuring range	0...100 Pa 0...300 Pa 0...600 Pa
Mesuring principle	Inductive membrane differential pressure measurement
Output signal	DC 0...10 V (proportional pressure for VRP...)
Linearity	±1% from extreme value (FS)
Histeresis	0.1% typ.
Temperature influence	
• zero position	±0.1% / K ±0.05% / K ±0.05% / K
• Mesuring range	±0.1% / K
	t = +10...+40°C (referent temperature to = 5°C)
Installation position	Vertical
Position dependance	Max. ±4,5 Pa za 90° rotation from horizontal
Electric connection	Cable 1 m , with 4 pole connector
Protection class	III (safety extra-low voltage) IP4
Operating temperature	0...+50°C
Storage temperature	-0...+80°C
Humidity test	to EN 60335-1

MOTOR DRIVE - BELIMO

	Type	Drive	Characteristics
Standard drives 0..90°	LM24A-V		- Motor drive VAV-Universal - AC/DC 24 V, modulating, 5 Nm - Control DC 6.0 ±4 V from VRP controller - Operating cycle 110 ... 150 s - Deflection angle 90°
	NM24A-V		- Motor drive VAV-Universal - AC/DC 24 V, modulating, 10 Nm - Control DC 6.0 ±4 V from VRP controller - Operating cycle 120 s - Deflection angle 90°
	SM24A-V		- Motor drive VAV-Universal - AC/DC 24 V, modulating, 10 Nm - Control DC 6.0 ±4 V from VRP controller - Operating cycle 120 s - Deflection angle 90°
Drives with spring return 0 ... 90°	LF24-V		- Motor drive with return spring VAV-Universal - AC/DC 24 V, modulating, 4 Nm - Control DC 6.0 ±4 V from VRP controller - Operating cycle 10...300 s - Spring working cycle 20 s - Deflection angle 95°
	AF24-V		- Motor drive with return spring VAV-Universal - AC/DC 24 V, modulating, 15 Nm - Control DC 6.0 ±4 V from VRP controller - Operating cycle 10...300 s - Spring working cycle 16 s - Deflection angle 95°